

User Guide

# Manhole Box

---



## Product Information

### **Overview**

---

A ground support system for forming a concrete manhole.

The Conquip Manhole Box is a two-sided, trench lining support system designed to be installed by simply lowering into an excavation via a crane.

The size of the system required depends on the maximum trench depth and the diameter of the pipe sections. High Clearance Adaptor Brackets can be supplied for applications where larger diameter pipes are required.

### **Key Benefits**

- Designed for use with both Conquip Incremental and Conquip Variable Struts.
- Manufactured from high quality British and European steel.
- Can be supplied with High Clearance Adaptor Brackets for larger width pipes.
- High Clearance Adaptor Brackets allow for 1643mm clearance below strut.
- A full range of suitable lifting and extraction chains, edge protection and trench access accessories are available on request.

The Manhole Box complies with the design codes listed below:

- AS 4100:2020- Steel Structure
- AS4744.1-2000 Steel shoring and trench lining equipment- Part 1: Design

## Product Information Specification

Item	Product Code
Manhole Box Base Box	TL103-00019
Manhole Box Extension Box	TL103-00020

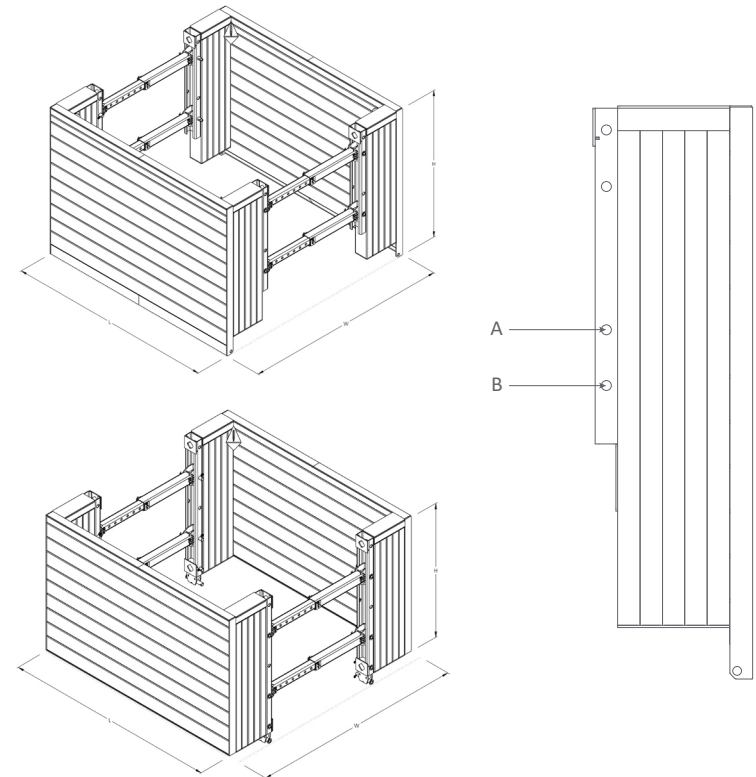

<sup>1</sup>Weight will be equal to or less than the weight stated depending on your strut configuration.

Item	Product Code	Height	Length	External Width	Max Weight <sup>1</sup>
Base Box	TL103-00019	2150mm	3000mm	2270-2970mm	2545kg
Extension Box	TL103-00020	1920mm	3000mm	2270-2970mm	2480kg

Product Information  
Specification

Front View

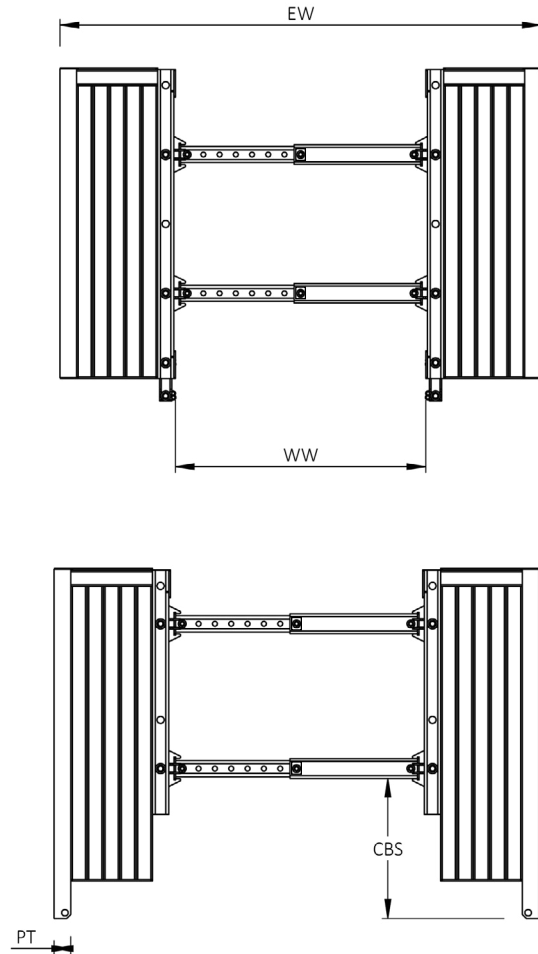

<sup>1</sup>When using the High Clearance Adaptor bracket the clearance below strut is 1643mm

Item	Product Code	Working Width	Clearance Below Strut <sup>1</sup>	Panel Thickness	Lifting Point Pulling Force
Base Box	TL103-00019	2060-3960mm	861mm	102mm	12562.5N
Extension Box	TL103-00020	2060-3960mm	861mm	102mm	12562.5N

Product Information  
Specification

Top View

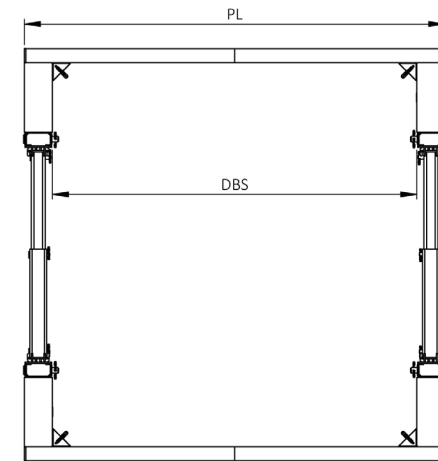

Side View

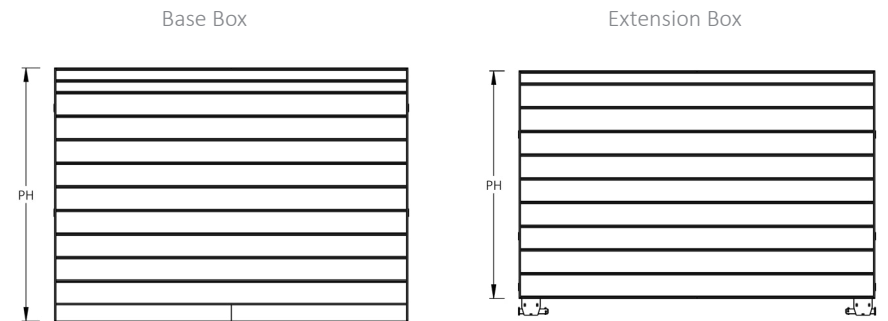

Item	Product Code	Panel Height	Panel Weight	Distance Between Struts
Base Box	TL103-00019	2150mm	1140kg	2600mm
Extension Box	TL103-00020	1920mm	1115kg	2600mm

## Product Information

# Parts Diagram

### Incremental Strut Assembly

#### One Section Strut

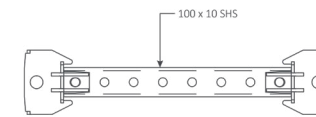

#### Two Section Strut

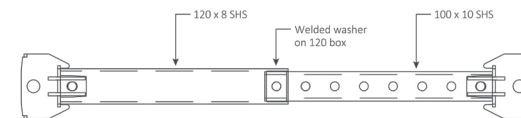

#### Three Section Strut

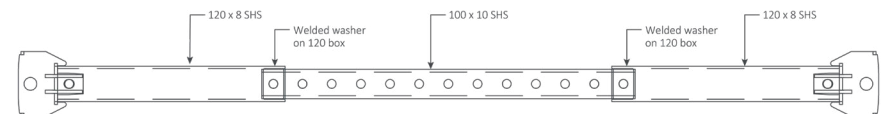

**▲ NOTE:** Three Section Struts must always be built with the 120box sections on the outside, washers facing inwards as shown above.

Product Information  
**Parts Diagram**

**Manhole Base Box**

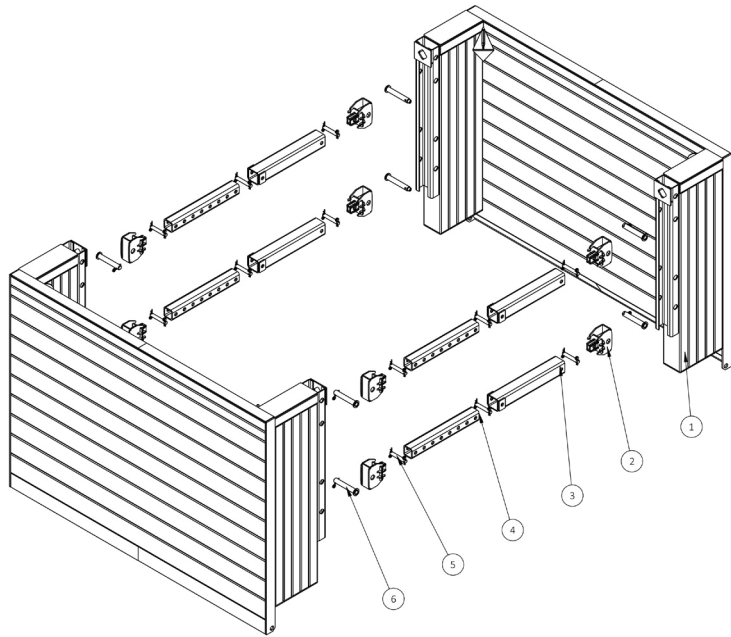

NOTE: These parts are for this model, they may differ for previous versions. Please contact Conquip with any queries.

Item Number	Part Number	Description	Quantity
1	TL900278	Manhole Box Base Panel 3000mm x 2150mm	2
2	TL900041	Rocker Assembly	8
3	TL900294	28mm Pin Assembly	12
4	TL900047	100x100x10 Strut Section w/ Adjustable Holes 780mm	4
5	TL900293	120x120x780 Incremental Strut Section	4
6	TL900043	40mm Pin Assembly	8

Product Information  
**Parts Diagram**

**Manhole Extension Box**

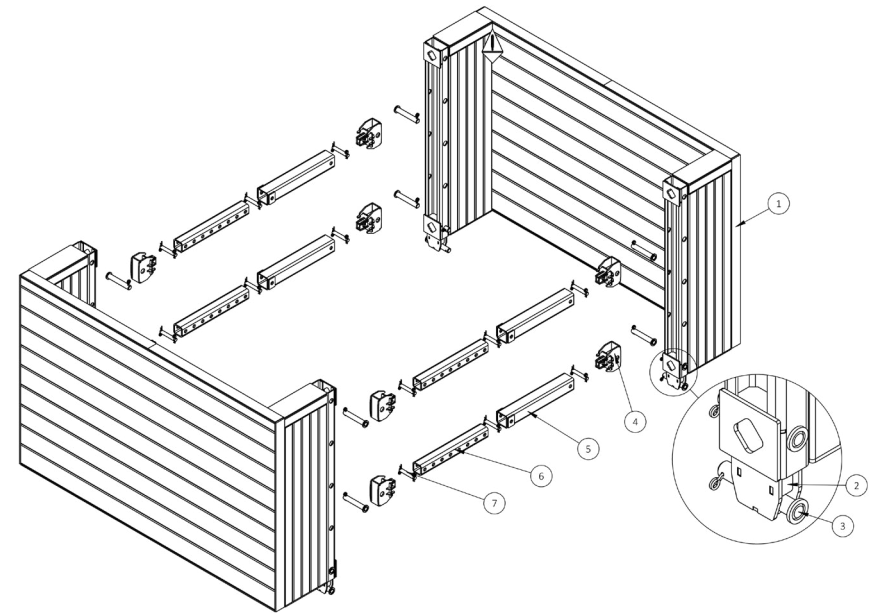

NOTE: These parts are for this model, they may differ for previous versions. Please contact Conquip with any queries.

Item Number	Part Number	Description	Quantity
1	TL900279	Manhole Box Extensions Panel 3000mm x 1920mm	2
2	TL900046	Connector Assembly	4
3	TL900043	40mm Pin Assembly	26
4	TL900041	Rocker Assembly	8
5	TL900294	28mm Pin Assembly	12
6	TL900047	100x100x10 Strut Section w/ Adjustable Holes 780mm	4
7	TL900293	120x120x780 Incremental Strut Section	4

## Original Working Instructions

# Usage Instructions

---

### Important Usage Instructions

- No personnel should be in the trench when the Trench Box is being installed or removed.
- The Trench Base Box is craned into the trench first at the required width.
- The Trench Extension Box is then craned in on top and attached using the connector assembly (TL900046) and the 40mm pin assembly (TL900043).

### Important Assembly Notes

- Top extension boxes are to be assembled in the same way but only two struts should be fitted. Extension boxes are secured to the base boxes using connector brackets and pins.
- Keep hands clear of naked surfaces.

### Assembly instructions

1. Using a certified lifting sling connected to the four corner lifting points, lift the panel onto some bearers and using the pins provided connect the rocker assembly to the panel. (Fig 1.1)
2. Place all four struts onto the rockers protruding from the panel facing upwards and secure them using the pins and R-clips supplied. (Fig 1.2)
3. Then connect the four remaining rocker assemblies to the struts using the
4. 40mm pins and R-clips supplied. Connect the sling to the lifting points of the panel facing downwards and lift it into position above the struts.
5. Lower the plate carefully, guiding the runners onto the four upright strut assemblies.
6. Secure the struts to the panel with the remaining four pins and R-clips. (Fig 1.3)
7. Disconnect the lifting sling connection points from the two lower lifting points and lift the box to the upright working position.
8. Connect the two free legs of the lifting sling to the upper lifting points of the other panel before lifting the box into the trench.

**Fig 1.1**

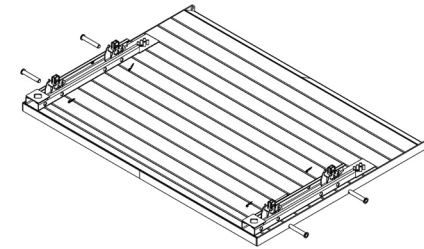

**Fig 1.2**

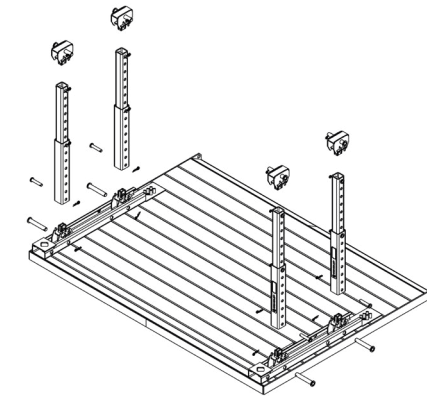

**Fig 1.3**

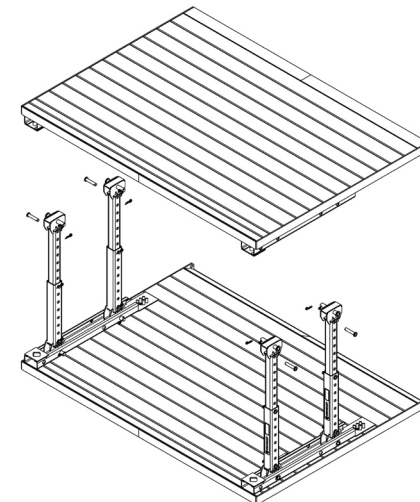

## Original Working Instructions

# Usage Instructions

### Connecting Extensions Boxes

1. The base box and extension box are connected via a connector bracket.
2. The connector bracket will fit within the panel soldier of the base box and is secured using a 40mm pin and R-clip.
3. The extension box is then placed on top of the base box. The protruding connector bracket must lock into the top of the panel soldier of the extension box.
4. Once in place, insert a 40mm  $\varnothing$  pin through the panel soldier and connector bracket. Secure with an R-clip.

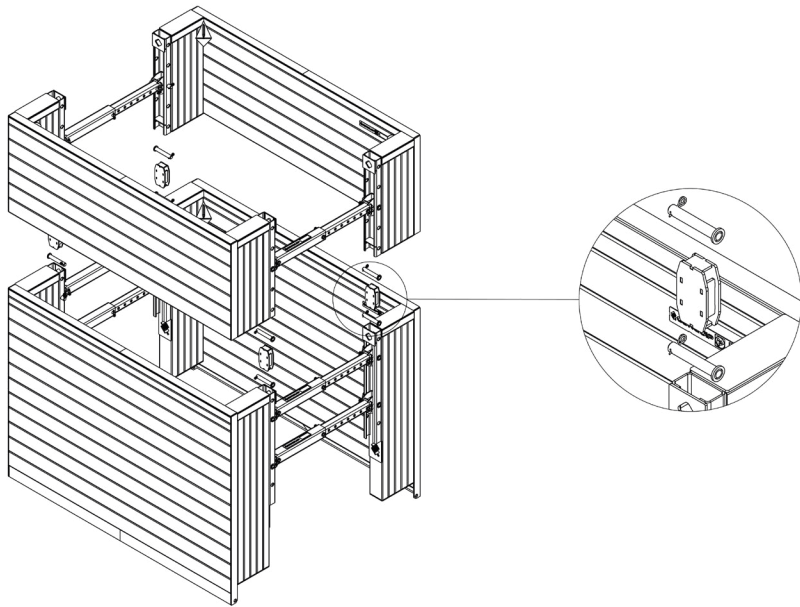

## Original Working Instructions

# Usage Instructions

### Important Installation Notes

- All personnel involved in installation must wear relevant personal protective equipment.
- Never enter an unsupported excavation.
- Stage 6 should be carried out when the top of the base is approximately 200mm above ground level.
- It is mandatory to use edge protection when carrying out trench support.
- Conquip recommends using the excavator 'dig and push' method where possible. However, if the ground is too hard, or if using the High Clearance Adaptor, lower the Manhole Box into the trench with lifting chains.

### Installation Instructions

1. Excavate the ground to approximately 1m or deeper, as ground conditions permit.
2. Lower the box into the trench using a certified 4 leg chain sling of the correct volume.
3. The excavator operator then digs progressively between the two faces of the box panels.
4. The operator then uses the back of the bucket of the excavator to push down on the 4 corners of the box in turn.
5. Repeat steps 3 and 4 until the desired depth is reached.
6. When attaching an extension box, they should be attached to the base box at each corner, using connectors supplied. Each connector is secured using a pair of pins and R-clips.
7. Once the extension box has been attached, use the dig and push technique until the Manhole Box assembly is at the desired depth.
8. Add Edge Protection panels to secure the area.

### Extraction

1. Backfill the excavation around the extension box.



## Original Working Instructions

### Usage Instructions

#### Extraction continued...

2. Attach a certified lifting chain to one of the top lifting points on the extension box.
3. Slowly lift the corner of the extension box.
4. Repeat this process for each opposite lifting point in turn until the extension box is 90cm above the ground.
5. Loosen the telescopic clamps and remove the Edge Protection panels.
6. Backfill the trench.
7. Reattach a certified lifting chain to one of the top lifting points on the extension box.
8. Lift the corner of the extension box. Repeat this process for each opposite lifting point in turn until the base box is 90cm above ground level.
9. Attach a suitably rated 4 leg chain sling to the top lifting points on the extension box.
10. Remove the R-clips and pins to disconnect the extension box from the base box.
11. Slowly lift and move the extension box away from the excavation.
12. Remove the R-clips, pins and the connectors from the base box.
13. Backfill the trench and extract the base box using the same method.
14. Attach a suitably rated 4 leg chain sling to the top lifting points on the base box and move away from the excavation.
15. Once all Trench Boxes have been successfully extracted, fill in the remainder of the trench and remove all equipment from the area.

## Product Information

### Specification

Item	Product Code
High Clearance Adaptor Bracket	TL900273

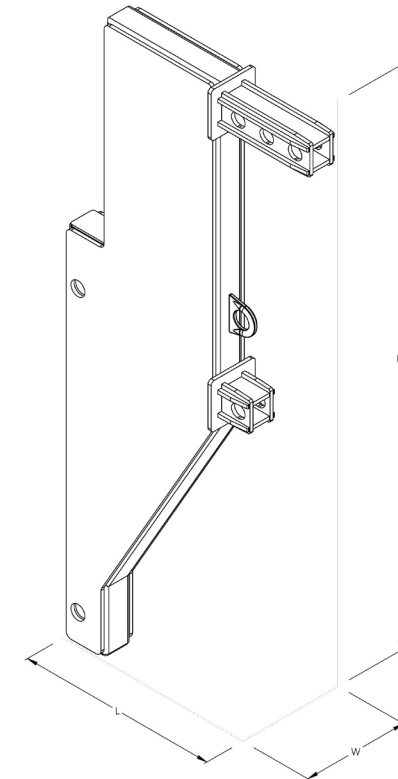

Product Code	Height	Length	Width	Weight
TL900273	180mm	770mm	140mm	155kg

## Original Working Instructions

# Usage Instructions

### Important Usage Instructions

- No personnel should be in the trench when the Manhole Box is being installed or removed.
- The High Clearance Adaptor Brackets must be fitted to the Manhole Box before it is crane lifted into the trench.

### Important Assembly Notes

- The High Clearance Adaptor Brackets weigh 155kg each and must not be manually lifted.
- Keep hands clear of naked surfaces.

### Assembly Instructions

1. Connect a certified lifting chain to the lifting points of a High Clearance Adaptor Bracket (HCAB) and lift onto some timber bearers.
2. Slot a fixed strut over the top extension point and secure with 3 x 35mm pins.
3. Repeat this process for the bottom extension point and secure with 1 x 35mm pin. (Fig 2.1)
4. Lift the opposite HCAB onto the timber bearers and repeat steps 2 & 3. The HCAB assembly is now complete. (Fig 2.2)
5. Repeat steps 1-4. Two HCAB assemblies are now complete.
6. Connect a certified lifting chain to the lifting points of the Shoring Box panel and lift onto some timber bearers laying it flat with the inside facing upwards.
7. Using appropriate lifting apparatus, lift one of the HCAB assemblies above the Shoring Box panel and lower into the c-section bracket. Secure with 40mm pins and R-clips.
8. Repeat step 7 for the other HCAB assembly. (Fig 2.3)
9. Connect a certified lifting chain to the lifting points of the other Shoring Box panel and lower onto the HCAB assemblies until the brackets slot into the panel c-sections.
10. Secure the Shoring Box panel to the HCAB assemblies with 40mm pins. (Fig 2.4)

Fig 2.1

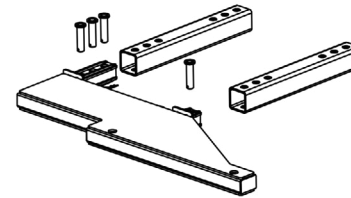

Fig 2.2

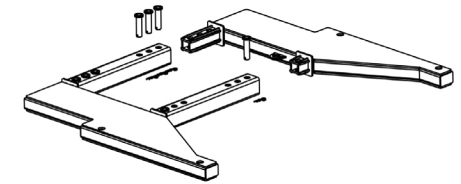

Fig 2.3

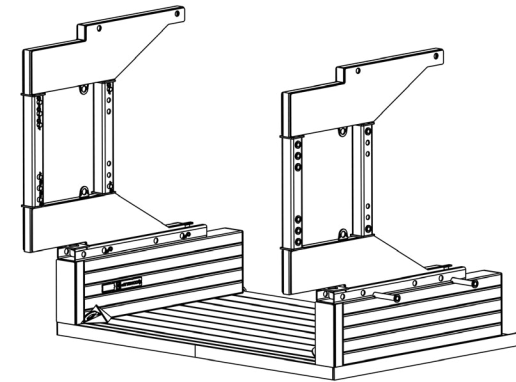
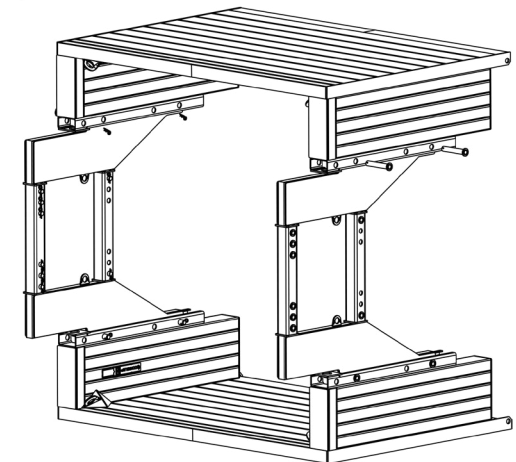

Fig 2.4



## Original Working Instructions

# Usage Instructions

---

### Installation Instructions

1. Excavate the ground to the desired trench depth as ground conditions permit.
2. Lower the Manhole Box into the trench using a certified 4 leg chain sling of the correct volume.
3. Backfill around the Manhole Box

### Extraction Instructions

1. Start by backfilling the trench.
2. Progressively pull the box upwards using a certified 4 leg lifting chain sling.
3. If extension boxes have been used, these should be disconnected as the joint becomes clear of the ground and then lifted clear before reconnecting the sling to the Base Box and continuing the extraction.

## Original Working Instructions

# Safety Instructions

---

### Basic Safety

A site-specific Risk Assessment, and lift plan where applicable, must be completed by the responsible person before using this equipment to control risks, produce a safe system of work and ensure safety for you, your colleagues and others. Your risk assessment will determine the correct Personal Protective Equipment (PPE) for the task you are doing. You must use it. Conquip recommends that you should wear:

- Suitable clothing
- Gloves
- Hard hat
- Protective footwear (steel toecaps)
- Safety glasses



### Important Safety Notes

- Read these instructions before using this equipment. If there is anything you do not understand or if you have any concerns do not use this equipment. Contact your supervisor or Conquip Engineering Group for advice.
- You must check that you have considered all the safety requirements for the task you are doing and that this equipment is suitable.
- You must protect bystanders and the general public by preventing access to the working area.
- Do not use this equipment if you are tired, unwell or under the influence of alcohol or drugs. If you are taking any medicine or undergoing treatment you should inform your supervisor.

## Usage & Transportation

- Never unevenly load this equipment.
- The weight of the equipment, together with its attachments, must be added to the weight of the load when calculating the total load that will be imposed on the lifting apparatus / operating machine.
- This equipment must be used in conjunction with the load ratings of the lifting apparatus / operating machine. (Refer to the manufacturers' load ratings and original working instructions).
- Make sure you know how to use this equipment and understand all aspects of its operation in case of emergency.
- This equipment weighs more than 25kg. Do not lift or manhandle without machine assistance.
- Do not operate this equipment near overhead power lines.
- Take care in confined spaces, near ceilings or similar hazards. This equipment was designed for vertical lifting. Do not drag, or swing.
- Before operating this equipment, check that you have enough space for you to work safely and make sure that the working area is clear of hazards, obstructions and personnel.
- Before lowering equipment make sure that the landing zone is clear and capable of accepting the size and weight of the load.
- Crush Risk. Keep hands and feet clear of the equipment at all times to avoid injury.
- Do not exceed the maximum Working Load Limit (WLL) shown on the serial plate. Ensure that the WLL on the individual lift points is not exceeded.
- Before lifting, check that the load is secured, balanced and stable. Allow space for the equipment to move if the load shifts.

## Personnel

- All personnel must wear relevant personal protective equipment.
- Do not wear loose clothing or jewellery and tie back long hair to avoid becoming tangled or trapped in this equipment. You must make everyone in the work area aware of what you are doing.
- All personnel involved in the lifting operation must be competent to do so and must have been briefed in conjunction with this User Guide available from Conquip Engineering Group, the manufacturer.

## Equipment Maintenance & Cleaning

- It is mandatory that the equipment is thoroughly examined regularly, by a qualified engineer, to ensure compliance with relevant regulation/s. (Conquip recommend to carry out thorough examination every six months).
- This product may incorporate various loose and detachable items of lifting gear. Refer to the separate requirements for the safe use of those items.
- When not being used, store the unit in a clean, upright condition and in a safe place where it will be protected from thieves and unauthorised users.
- This equipment must be inspected by the responsible person before each use and then regularly, as determined by your risk assessment or working practice. If you have any concerns about condition or suitability do not use.

## Disclaimer

---

### Warranty

The products supplied by Conquip Engineering Group are all guaranteed by a 12 month warranty.

Apart from where exceptions apply, Conquip Engineering Group promises to repair or replace any fault which the Company considers to be due to defective material or workmanship within 12 months of the date of sale, at no additional cost.

- Faults arising from unauthorised alterations (see modifications section below for full details).
- Damage caused by abuse, neglect, misuse or falling.
- Damage caused because of failure to follow transportation, storage, loading, cleaning or operating instructions.
- Replacement or repair of components due to fair wear and tear.
- Any consequential damage or wear arising from the use or fitting of additional or non-standard parts.

### Modifications

If any third-party modifications or alterations, involving drilling, welding, cutting or distortion of materials in any form, are to be carried out on the product, Conquip Engineering Group must provide full written approval prior to the work being carried out.

Alterations, modifications, additions or repairs must be carried out by Conquip Engineering Group's recognised distributors, if they are not carrying out the work themselves.

Conquip Engineering Group operate a continuous improvement policy and therefore reserve the right to alter technical specifications and user guide details at any point without notice.

Conquip Engineering Group will not cover or reimburse any transportation and/or shipment costs to and from their premises or their recognised agents, or any material and/or labour costs for repair, replacement or assessment against a warranty claim.

Conquip Engineering Group and/or their directors, employees, insurers or recognised agents will not be held liable for consequential damages, losses or expenses relating to the inability to use the product correctly for its purpose.

### Standards & Regulations

This Manhole Box shoring system has been certified by a Professional Engineer licenced in Australia (BE ME PhD MIE Aust. NER RPEQ) in accordance with the relevant Australian design standards.

## Important Notes

- This User Guide is for this Conquip product only.
- Any movements of the product must be thoroughly planned before the work commences to identify potential hazards and assess risk.
- All personnel involved in lifting and transportation of this product must have read this User Guide and must be properly briefed.
- You must be competent, alert and medically fit when using this equipment. If you have a medical condition, a mental or physical disability, you must seek advice from a medical professional before using this equipment.

Talking to us is easy  
**We're here to help**

Call us on (02) 8844 4590  
Email us at [sales@conquipgroup.com.au](mailto:sales@conquipgroup.com.au)  
[www.conquipgroup.com.au](http://www.conquipgroup.com.au)