

User Guide

Goods Cage



Product Information

Overview

Conquip Goods Cage is a safe, convenient method of transporting materials to and from high or low locations on site. It is fitted with four fully tested lifting points for crane lifting, and fork pockets are included as standard for easy manoeuvrability.

There are two standard sizes of the goods cage, either with a gas assisted ramp or a secure gate. The ramp offers the ability to load the cage using pallet truck and sack barrows.

Key Benefits

- Variety of sizes and options for different requirements, can be manufactured to exact specification.
- Easy loading due to front gate, or fold down ramp on some options.
- Safe and secure for transporting loads.
- Manufactured in the UK from quality British and EU steel.
- All standard Conquip Goods Cages have a minimum Working Load Limit of 3000kg.

Product Information Specification

Item	Product Code
Goods Cage 1638	CA118AL-01638
Ramped Goods Cage 1658	CA124AL-01658

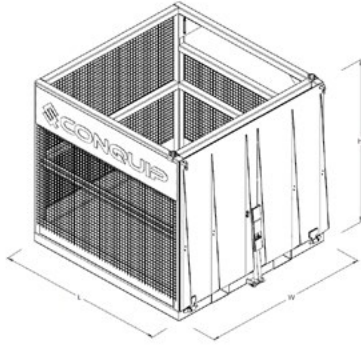

¹Working Load Limit

Product Code	Height	Width	Length	Weight	WLL ¹	Fork Pocket
CA118AL-01638	1280mm	1280mm	1280mm	270kg	3000kg	150 x 70mm
CA124AL-01658	1300mm	1300mm	1360mm	300kg	3000kg	150 x 70mm

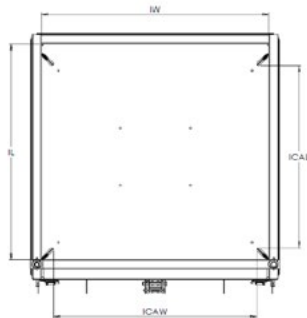

Product Code	Internal Width	Internal Length	Internal Clear Area Width	Internal Clear Area Length
CA118AL-01638	1180mm	1176mm	1055mm	956mm
CA124AL-01658	1180mm	1130mm	1055mm	956mm

Product Information Specification

Item	Product Code
Goods Cage 3277	CA118AL-03277
Short End Ramped Goods Cage 3277	CA124AK-03277
Long End Ramped Goods Cage 3277	CA124AL-03277

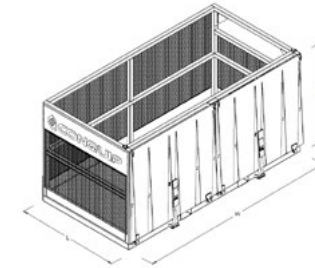

¹Working Load Limit

Product Code	Height	Width	Length	Weight	WLL ¹	Fork Pocket
CA118AL-03277	1280mm	1280mm	2560mm	450kg	3000kg	150 x 70mm
CA124AK-03277	1280mm	1300mm	2645mm	460kg	3000kg	150 x 70mm
CA124AL-03277	1300mm	1300mm	2560mm	500kg	3000kg	150 x 70mm

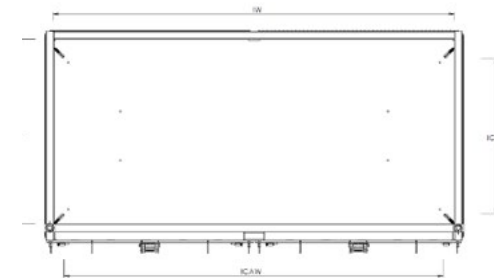

Product Code	Internal Width	Internal Length	Internal Clear Area Width	Internal Clear Area Length
CA118AL-03277	1173mm	2460mm	994mm	2309mm
CA124AK-03277	1180mm	2410mm	1055mm	2276mm
CA124AL-03277	1130mm	2460mm	994mm	2309mm

Product Information Parts Diagram

Goods Cage 1638

There are no replaceable parts on this option.

Ramped Goods Cage 1658

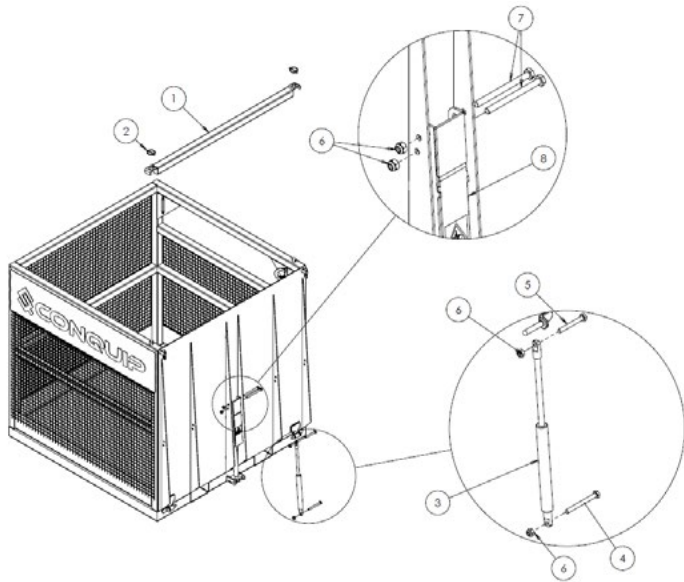

NOTE: These parts are for this model, they may differ for previous versions. Please contact Conquip with any queries.

Item Number	Part Number	Description	Quantity
1	ZZ190060	Spreader Beam Assembly	1
2	ZZ990009	6mm Linch Pin	2
3	ZZ960042	Gas Strut 1500N 14 x 200mm	2
4	NS800425	M10 x 100 Hex Head Set Screw	1
5	NS800917	M10 x 80 Hex Head Set Screw	1
6	NS800013	M10 Nyloc Nut	4
7	NS800480	M10x120 Hex Head Set Screw 8.8	2
8	ZZ190067	Gas Strut Pre-tension lever assembly	1

Product Information Parts Diagram

Goods Cage 3277

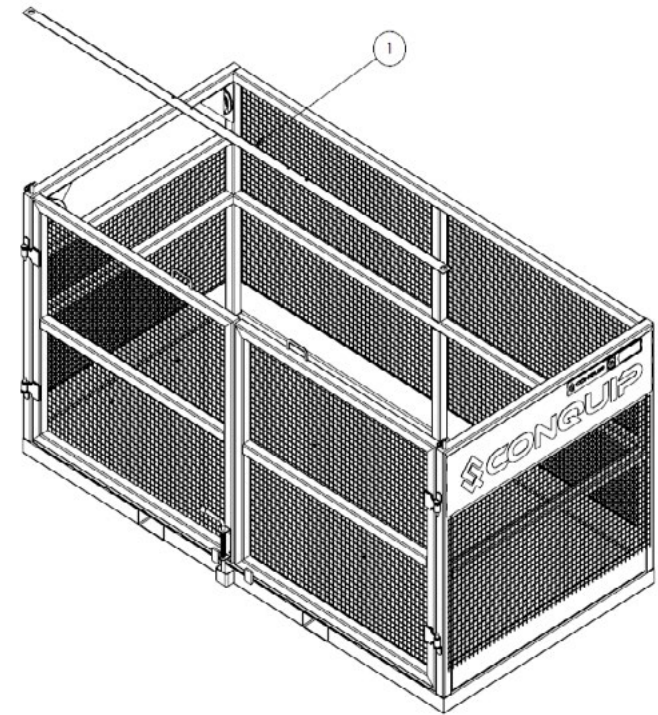

NOTE: These parts are for this model, they may differ for previous versions. Please contact Conquip with any queries.

Item Number	Part Number	Description	Quantity
1	ZZ190061	Door Brace Assembly	1

Product Information
Parts Diagram

Short End Ramped Goods Cage 3277

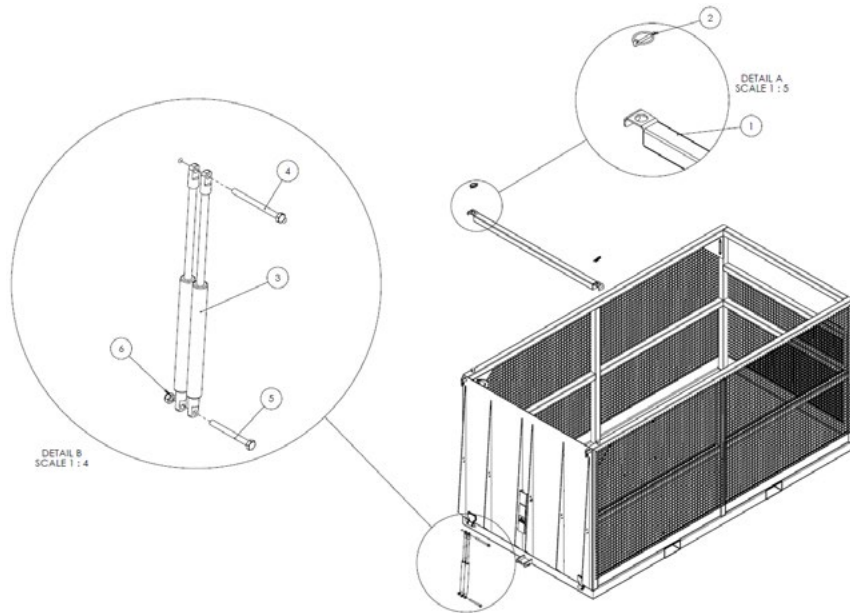

NOTE: These parts are for this model, they may differ for previous versions. Please contact Conquip with any queries.

Item Number	Part Number	Description	Quantity
1	ZZ190060	Spreader Beam Assembly	1
2	ZZ990009	6mm Linch Pin	2
3	ZZ960042	Gas Strut 1500N 14 x 200mm	2
4	NS800480	M10 x 120 Hex Head Set Screw	1
5	NS800425	M10 x 100 Hex Head Set Screw	1
6	NS800013	M10 Nyloc Nut	2

Product Information
Parts Diagram

Long End Ramped Goods Cage 3277

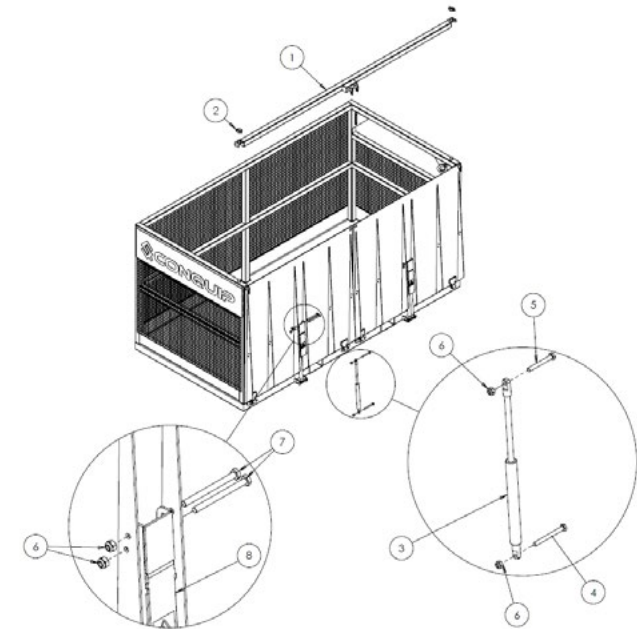

NOTE: These parts are for this model, they may differ for previous versions. Please contact Conquip with any queries.

Item Number	Part Number	Description	Quantity
1	ZZ190059	Spreader Beam Assembly	1
2	ZZ990009	6mm Linch Pin	2
3	ZZ960042	Gas Strut 1500N 14 x 200mm	4
4	NS800425	M10 x 120 Hex Head Set Screw	4
5	NS800917	M10 x 80 Hex Head Set Screw	2
6	NS800013	M10 Nyloc Nut	8
7	NS800480	M10x120 Hex Head Set Screw 8.8	4
8	ZZ190067	Gas Strut Pre-tension lever assembly	2

Original Working Instructions

Usage Instructions

Important Usage Notes

- Do not unevenly load the Goods Cage.
- The Goods Cage must only be lifted by the designated four lifting points or the integral fork pockets.
- Make sure the new location is safe for personnel access before moving the load.

Using with a Crane

1. Load the cage using the access door or fold down ramp for access.
2. Secure the load if there is room for movement within the cage.
3. Once the supervisor is happy that the load is secure, balanced, and does not exceed maximum loading weights, attach a suitable rated chain sling to the four lifting points at each of the corners of the cage.
4. Check that personnel are clear from the immediate area and the future location to allow for swing of the cage when lifting off the ground.
5. Crane or fork lift to location and lower onto a firm, stable, flat surface.
6. Unload the materials, using the door or ramp.

Original Working Instructions

Safety Instructions

Basic Safety

A site-specific Risk Assessment, and lift plan where applicable, must be completed by the responsible person before using this equipment to control risks, produce a safe system of work and ensure safety for you, your colleagues and others. Your risk assessment will determine the correct Personal Protective Equipment (PPE) for the task you are doing. You must use it. Conquip recommends that you should wear:

- Suitable clothing
- Gloves
- Hard hat
- Protective footwear (steel toecaps)
- Safety glasses



Important Safety Notes

- Read these instructions before using this equipment. If there is anything you do not understand or if you have any concerns do not use this equipment. Contact your supervisor or Conquip Engineering Group for advice.
- You must check that you have considered all the safety requirements for the task you are doing and that this equipment is suitable.
- You must protect bystanders and the general public by preventing access to the working area.
- Do not use this equipment if you are tired, unwell or under the influence of alcohol or drugs. If you are taking any medicine or undergoing treatment you should inform your supervisor.

Usage & Transportation

- Never unevenly load this equipment.
- The weight of the equipment, together with its attachments, must be added to the weight of the load when calculating the total load that will be imposed on the lifting apparatus / operating machine.
- This equipment must be used in conjunction with the load ratings of the lifting apparatus / operating machine. (Refer to the manufacturers' load ratings and original working instructions).
- Make sure you know how to use this equipment and understand all aspects of its operation in case of emergency.
- This equipment weighs more than 25kg. Do not lift or manhandle without machine assistance.
- Do not operate this equipment near overhead power lines.
- Take care in confined spaces, near ceilings or similar hazards. This equipment was designed for vertical lifting. Do not drag, or swing.
- Before operating this equipment, check that you have enough space for you to work safely and make sure that the working area is clear of hazards, obstructions and personnel.
- Before lowering equipment make sure that the landing zone is clear and capable of accepting the size and weight of the load.
- Crush Risk. Keep hands and feet clear of the equipment at all times to avoid injury.
- Do not exceed the maximum Working Load Limit (WLL) shown on the serial plate. Ensure that the WLL on the individual lift points is not exceeded.
- Before lifting, check that the load is secured, balanced and stable. Allow space for the equipment to move if the load shifts.
- Manoeuvre loaded or raised equipment carefully. Travel and turn slowly to avoid unit becoming unstable.

Personnel

- All personnel must wear relevant personal protective equipment.
- Do not wear loose clothing or jewellery and tie back long hair to avoid becoming tangled or trapped in this equipment. You must make everyone in the work area aware of what you are doing.
- All personnel involved in the lifting operation must be competent to do so and must have been briefed in conjunction with this User Guide available from Conquip Engineering Group, the manufacturer.

Equipment Maintenance & Cleaning

- It is mandatory that the equipment is thoroughly examined regularly, by a qualified engineer, to ensure compliance with relevant regulation/s. (Conquip recommend to carry out thorough examination every six months).
- This product may incorporate various loose and detachable items of lifting gear. Refer to the separate requirements for the safe use of those items.
- When not being used, store the unit in a clean, upright condition and in a safe place where it will be protected from thieves and unauthorised users.
- This equipment must be inspected by the responsible person before each use and then regularly, as determined by your risk assessment or working practice. If you have any concerns about condition or suitability do not use.

Disclaimer

Warranty

The products supplied by Conquip Engineering Group are all guaranteed by a 12 month warranty.

Apart from where exceptions apply, Conquip Engineering Group promises to repair or replace any fault which the Company considers to be due to defective material or workmanship within 12 months of the date of sale, at no additional cost.

- Faults arising from unauthorised alterations (see modifications section below for full details).
- Damage caused by abuse, neglect, misuse or falling.
- Damage caused because of failure to follow transportation, storage, loading, cleaning or operating instructions.
- Replacement or repair of components due to fair wear and tear.
- Any consequential damage or wear arising from the use or fitting of additional or non-standard parts.

Modifications

If any third-party modifications or alterations, involving drilling, welding, cutting or distortion of materials in any form, are to be carried out on the product, Conquip Engineering Group must provide full written approval prior to the work being carried out.

Alterations, modifications, additions or repairs must be carried out by Conquip Engineering Group's recognised distributors, if they are not carrying out the work themselves.

Conquip Engineering Group operate a continuous improvement policy and therefore reserve the right to alter technical specifications and user guide details at any point without notice.

Conquip Engineering Group will not cover or reimburse any transportation and/or shipment costs to and from their premises or their recognised agents, or any material and/or labour costs for repair, replacement or assessment against a warranty claim.

Conquip Engineering Group and/or their directors, employees, insurers or recognised agents will not be held liable for consequential damages, losses or expenses relating to the inability to use the product correctly for its purpose.

EC Declaration of Conformity

In accordance with EN ISO 17050-1:2004

Declaration: As defined by the Machinery Directive 2006/42/EC and subsequent amendments

We, CONQUIP ENGINEERING GROUP, herewith declare that the following indicated equipment meets the fundamental health and safety requirements concerning the EU guide line(s), due to their design and manufacture.

This declaration will be rendered null and void if the machine is changed without our approval.

Signed:



Dated: 2019

Garry Critchley, Managing Director

Product Code(s):	CA118AL-01638 / CA118AL-03277 / CA124AL-01658 / CA124AK-03277 / CA124AL-03277
EC Directive/ Regulation:	2006/42/EC, Lifting Operations and Lifting Equipment Regulations 1998 Provision and Use of Work Equipment Regulations 1998
Harmonised Standards:	BS EN ISO 12100:2010 BS EN 13155
General Description/ Designation:	Goods Cage 1638- CA118AL-01638 Goods Cage 3277- CA118AL-03277 Ramped Goods Cage 1658- CA124AL-01658 Short End Ramped Goods Cage 3277- CA124AK-03277 Long End Ramped Goods Cage 3277- CA124AL-03277
WLL:	CA118AL-01638 / CA118AL-03277 / CA124AL-01658 / CA124AK-03277 / CA124AL-03277 = 3000kg

Important Notes

- This User Guide is for this Conquip product only.
- Any movements of the product must be thoroughly planned before the work commences to identify potential hazards and assess risk.
- All personnel involved in lifting and transportation of this product must have read this User Guide and must be properly briefed.
- You must be competent, alert and medically fit when using this equipment. If you have a medical condition, a mental or physical disability, you must seek advice from a medical professional before using this equipment.

Talking to us is easy

We're here to help

Call us on 0845 520 1101

Email us at sales@cqegroup.com

www.cqegroup.com

Conquip Engineering Group

Waterbrook Estate, Alton, Hampshire, GU34 2UD