

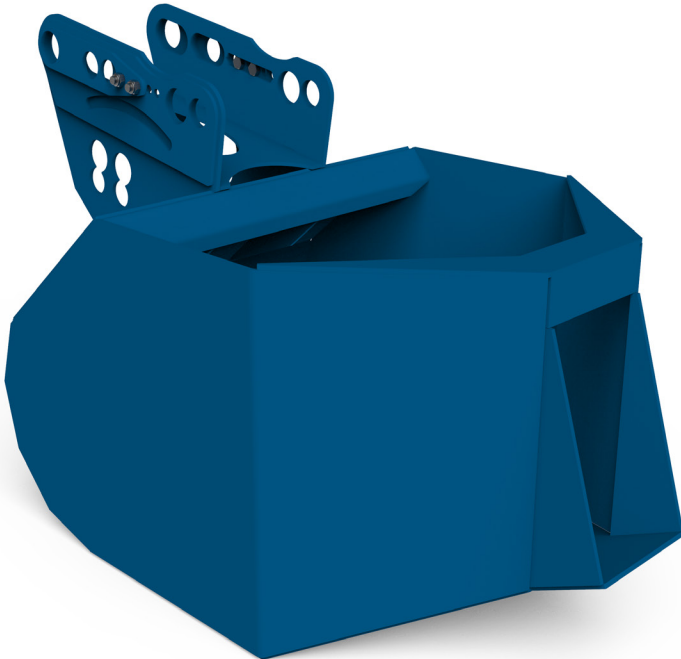

User Guide

Excavator Pouring Bucket



Product Information Overview

The Excavator Pouring Bucket is designed to pour concrete when attached to an excavator quick hitch. The concrete is discharged straight into the bucket from a concrete lorry, or similar, and can then be poured into the required area. It is especially beneficial for small sites and civils works, where a concrete skip or a concrete pump is not required.

It can be used to pour other materials, such as loose gravel. It is not designed to scoop material from a stockpile on the ground.

Key Benefits

- The bucket allows easy transportation of concrete to areas where a concrete lorry can't get to. The excavator can track across uneven ground to the pouring location.
- Quick and simple to attach, with adjustable pin centres and different pin sizes to suit any model of excavator quick hitch.
- Excavator Pouring Bucket 380 can be supplied with 45, 50 or 60mm pins to suit 5 to 9 tonne excavators.
- Excavator Pouring Bucket 700 can be supplied with 65 or 80mm pins to suit 13 to 22 tonne excavators.
- Excavator Pouring Bucket 1200 can be supplied with 90, 100 or 110mm pins to suit 30 to 50 tonne excavators.
- There is pin storage for the other size pins if you are needing to alternate use between different size excavators.
- The bucket can be filled directly from the concrete lorry, preventing double-handling.

Product Information Specification

Item	Product Code
Excavator Pouring Bucket 380	EA014AH-00380
Excavator Pouring Bucket 700	EA014AF-00700
Excavator Pouring Bucket 1200	EA014AF-01200

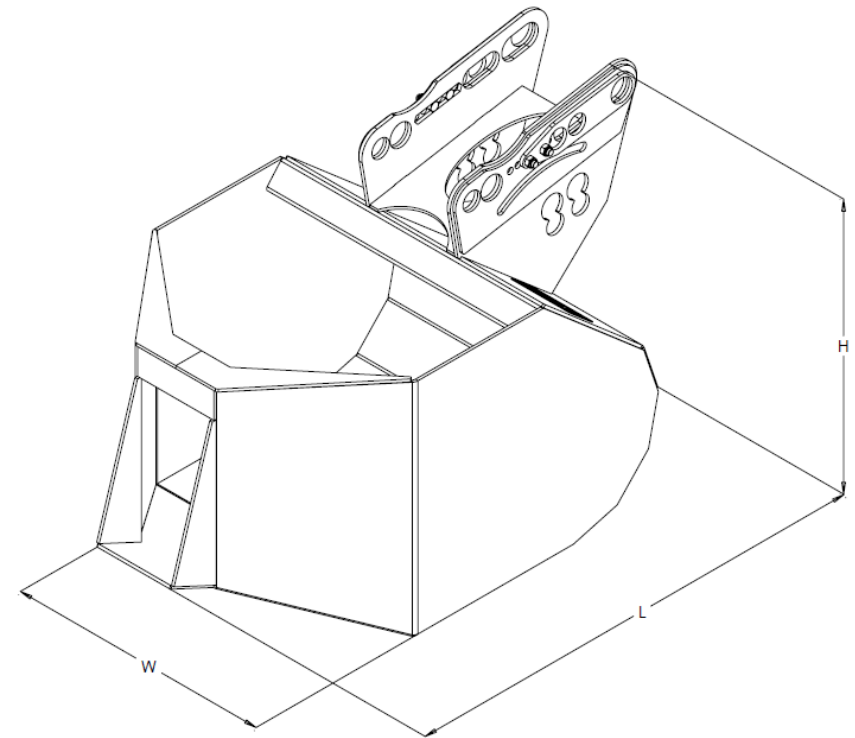

¹Working Load Limit

Product Code	Height	Width	Length	Weight	WLL ¹	Capacity
EA014AH-00380	1075mm	640mm	1520mm	155kg	1000kg	380 litres
EA014AF-00700	1210mm	1020mm	1775mm	460kg	2100kg	700 litres
EA014AF-01200	1220mm	1220mm	2240mm	610kg	3600kg	1200 litres

Original Working Instructions

Usage Instructions

Important Usage Notes

- Ensure this product is compatible with your excavator lifting table before using. (Refer to the manufacturer's user guide)
- Ensure that all personnel are clear of the excavator when manoeuvring and pouring. All personnel involved in process must be wearing relevant personal protective equipment.
- If using for pouring materials other than concrete, such as shingle or gravel, the bucket must be loaded by another piece of machinery. It is not designed to scoop material from a stockpile on the ground.

Using with an Excavator

1. Select correct size pins for your machine's quick hitch.
2. Fit front pin to correct sized hole on the attachment.
3. Adjust position of rear pin to suit the quick hitch – follow the quick hitch operating guidelines and set the pins to the maximum centres for the unit.
4. Ensure the quick hitch pins have the retaining bolt correctly fitted.
5. Check for debris in the quick hitch locking mechanism and check the fit of the unit on the quick hitch, do not use if not secure.
6. Ensure other pins, as available, are stored correctly to prevent loss.
7. Manoeuvre the excavator to the concrete lorry and position the bucket underneath the chute, tilted backwards slightly for maximum capacity.
8. Fill the bucket with concrete from the lorry. Do not overfill to prevent spillage when manoeuvring.
9. Drive the excavator to the pouring location and pour concrete, as required.

Original Working Instructions

Safety Instructions

Basic Safety

A site-specific Risk Assessment, and lift plan where applicable, must be completed by the responsible person before using this equipment to control risks, produce a safe system of work and ensure safety for you, your colleagues and others. Your risk assessment will determine the correct Personal Protective Equipment (PPE) for the task you are doing. You must use it. Conquip recommends that you should wear:

- Suitable clothing
- Gloves
- Hard hat
- Protective footwear (steel toecaps)
- Safety glasses



Important Safety Notes

- Read these instructions before using this equipment. If there is anything you do not understand or if you have any concerns do not use this equipment. Contact your supervisor or Conquip Engineering Group for advice.
- You must check that you have considered all the safety requirements for the task you are doing and that this equipment is suitable.
- You must protect bystanders and the general public by preventing access to the working area.
- Do not use this equipment if you are tired, unwell or under the influence of alcohol or drugs. If you are taking any medicine or undergoing treatment you should inform your supervisor.

Usage & Transportation

- Never unevenly load this equipment.
- The weight of the equipment, together with its attachments, must be added to the weight of the load when calculating the total load that will be imposed on the lifting apparatus / operating machine.
- This equipment must be used in conjunction with the load ratings of the lifting apparatus / operating machine. (Refer to the manufacturers' load ratings and original working instructions).
- Make sure you know how to use this equipment and understand all aspects of its operation in case of emergency.
- This equipment weighs more than 25kg. Do not lift or manhandle without machine assistance.
- Do not operate this equipment near overhead power lines.
- Take care in confined spaces, near ceilings or similar hazards. This equipment was designed for vertical lifting. Do not drag, or swing.
- Before operating this equipment, check that you have enough space for you to work safely and make sure that the working area is clear of hazards, obstructions and personnel.
- Before lowering equipment make sure that the landing zone is clear and capable of accepting the size and weight of the load.
- Crush Risk. Keep hands and feet clear of the equipment at all times to avoid injury.
- Do not exceed the maximum Working Load Limit (WLL) shown on the serial plate. Ensure that the WLL on the individual lift points is not exceeded.
- Before lifting, check that the load is secured, balanced and stable. Allow space for the equipment to move if the load shifts.
- Manoeuvre loaded or raised equipment carefully. Travel and turn slowly to avoid unit becoming unstable.

Personnel

- All personnel must wear relevant personal protective equipment.
- Do not wear loose clothing or jewellery and tie back long hair to avoid becoming tangled or trapped in this equipment. You must make everyone in the work area aware of what you are doing.
- All personnel involved in the lifting operation must be competent to do so and must have been briefed in conjunction with this User Guide available from Conquip Engineering Group, the manufacturer.

Equipment Maintenance & Cleaning

- It is mandatory that the equipment is thoroughly examined regularly, by a qualified engineer, to ensure compliance with relevant regulation/s. (Conquip recommend to carry out thorough examination every six months).
- This product may incorporate various loose and detachable items of lifting gear. Refer to the separate requirements for the safe use of those items.
- When not being used, store the unit in a clean, upright condition and in a safe place where it will be protected from thieves and unauthorised users.
- This equipment must be inspected by the responsible person before each use and then regularly, as determined by your risk assessment or working practice. If you have any concerns about condition or suitability do not use.

Disclaimer

Warranty

The products supplied by Conquip Engineering Group are all guaranteed by a 12 month warranty.

Apart from where exceptions apply, Conquip Engineering Group promises to repair or replace any fault which the Company considers to be due to defective material or workmanship within 12 months of the date of sale, at no additional cost.

- Faults arising from unauthorised alterations (see modifications section below for full details).
- Damage caused by abuse, neglect, misuse or falling.
- Damage caused because of failure to follow transportation, storage, loading, cleaning or operating instructions.
- Replacement or repair of components due to fair wear and tear.
- Any consequential damage or wear arising from the use or fitting of additional or non-standard parts.

Modifications

If any third-party modifications or alterations, involving drilling, welding, cutting or distortion of materials in any form, are to be carried out on the product, Conquip Engineering Group must provide full written approval prior to the work being carried out.

Alterations, modifications, additions or repairs must be carried out by Conquip Engineering Group's recognised distributors, if they are not carrying out the work themselves.

Conquip Engineering Group operate a continuous improvement policy and therefore reserve the right to alter technical specifications and user guide details at any point without notice.

Conquip Engineering Group will not cover or reimburse any transportation and/or shipment costs to and from their premises or their recognised agents, or any material and/or labour costs for repair, replacement or assessment against a warranty claim.

Conquip Engineering Group and/or their directors, employees, insurers or recognised agents will not be held liable for consequential damages, losses or expenses relating to the inability to use the product correctly for its purpose.

EC Declaration of Conformity

In accordance with EN ISO 17050-1:2004

Declaration: As defined by the Machinery Directive 2006/42/EC and subsequent amendments

We, CONQUIP ENGINEERING GROUP, herewith declare that the following indicated equipment meets the fundamental health and safety requirements concerning the EU guide line(s), due to their design and manufacture.

This declaration will be rendered null and void if the machine is changed without our approval.

Signed:



Dated: 2019

Garry Critchley, Managing Director

Product Code(s):	EA014AH-00380 / EA014AF-00700 / EA014AF-01200
EC Directive/ Regulation:	2006/42/EC, Lifting Operations and Lifting Equipment Regulations 1998 Provision and Use of Work Equipment Regulations 1998
Harmonised Standards:	BS EN ISO 12100:2010
General Description/ Designation:	Excavator Pouring Bucket 380- EA014AH-00380 Excavator Pouring Bucket 700- EA014AF-00700 Excavator Pouring Bucket 1200- EA014AF-01200
WLL:	EA014AH-00380 = 1000kg EA014AF-00700 = 2100kg EA014AF-01200 = 3600kg

Important Notes

- This User Guide is for this Conquip product only.
- Any movements of the product must be thoroughly planned before the work commences to identify potential hazards and assess risk.
- All personnel involved in lifting and transportation of this product must have read this User Guide and must be properly briefed.
- You must be competent, alert and medically fit when using this equipment. If you have a medical condition, a mental or physical disability, you must seek advice from a medical professional before using this equipment.

Talking to us is easy

We're here to help

Call us on 0845 520 1101

Email us at sales@cqegroup.com

www.cqegroup.com

Conquip Engineering Group

Waterbrook Estate, Alton, Hampshire, GU34 2UD