

User Guide

# Concrete Forklift Skip

---

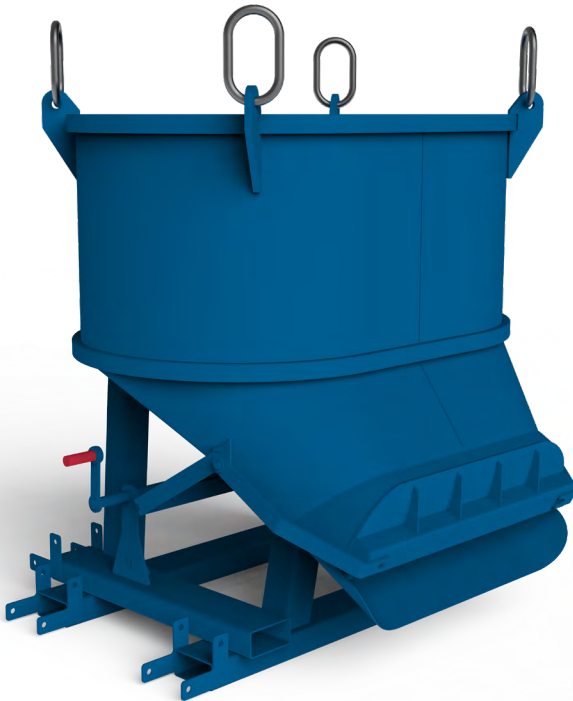

## Product Information Specification

Item	Product Code
Concrete Forklift Skip 500	CS214-00500
Concrete Forklift Skip 1000	CS214-01000

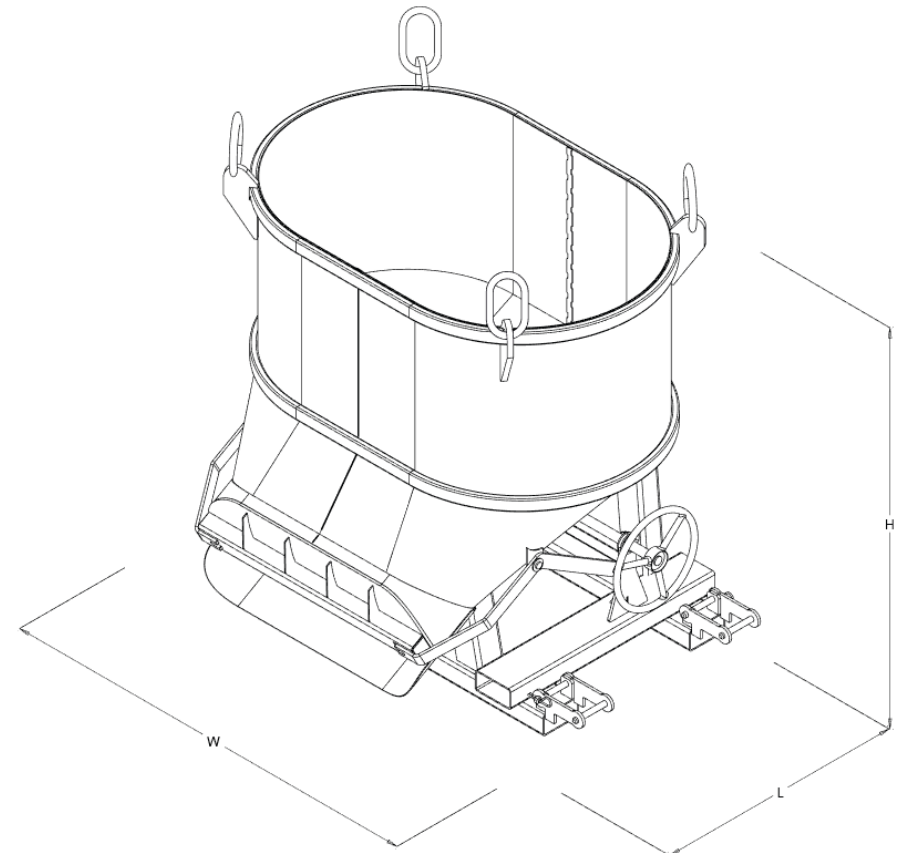

<sup>1</sup>Working Load Limit

Product Code	Height	Width	Length	Weight	WLL <sup>1</sup>	Capacity
CS214-00500	1350mm	1350mm	850mm	245kg	1500kg	500 litre
CS214-01000	1780mm	1530mm	1210mm	360kg	3000kg	1000 litre

## Product Information Overview

The Conquip Concrete Forklift Skip is a skip designed to be attached to a forklift for quick and easy manoeuvring and pouring of concrete. The geared opening aids easy flow and control of concrete pouring.

### Key Benefits

- The low overall height of the skip enables it to be filled from a site concrete mixer.
- Geared opening for easy concrete flow.

## Product Information

# Parts Diagram

### Concrete Forklift Skip

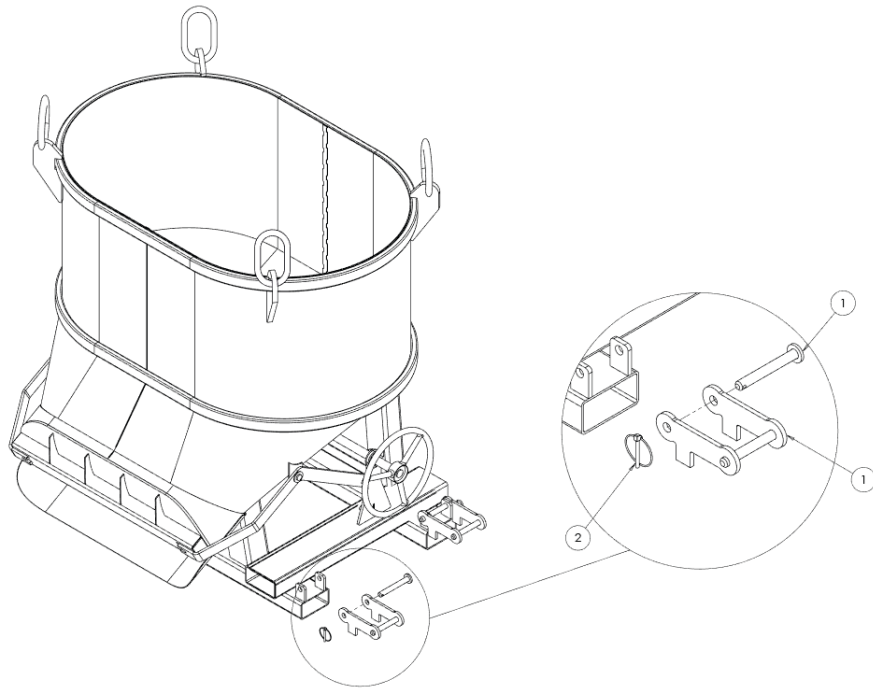

NOTE: These parts are for this model, they may differ for previous versions. Please contact Conquip with any queries.

Item Number	Part Number	Description	Quantity
1	ZZ11035	Heel Pin Assembly	4
2	ZZ990000	6mm Linch Pin	4

## Original Working Instructions

# Usage Instructions

### Important Usage Notes

- The Concrete Forklift Skip is supplied with heel pins; these must be fitted correctly before use.
- It is recommended that you apply skip wax to the skip to assist cleaning. This is available from Conquip.

### Usage Instructions

1. To attach the Concrete Forklift Skip to a forklift, first release the heel pins by removing the linch pins and pulling from the attachment. Set the machine's forks to the correct width for the Concrete Forklift Skip fork pockets. Make sure that they are equidistant from the centre.
2. Drive the forklift to the skip, aligning the forks with the skip's fork pockets.
3. Double check that all is correctly aligned, then move the forklift forward until the forks are fully inserted into the fork pockets.
4. Apply the park brake and switch off the forklift engine.
5. Insert the heel pins ensuring they pass behind the heel of the forks, use the linch pins to lock the heel pins in place.
6. Ensure the skip's flow gate is fully closed. The wheel should be turned clockwise to ensure it is fully closed and attach the safety chain to the wheel to prevent the gate opening during a lift.
7. Once prepared and ready to fill with concrete, manoeuvre the skip to the filling location and position the skip on the ground.
8. Fill the skip with concrete, taking care that the load is level. Do not overfill. The skip can now be raised and moved to where it is required.
9. Carefully raise the skip just off the ground and check for balance and security.
10. Carefully move the load to its required position. Move slowly and carefully; do not jolt the load.
11. When in position, lower the skip until the load is suspended above the discharge point.
12. Carefully open the gate by either depressing the lever or releasing the safety chain and turning the release wheel anticlockwise.

## Original Working Instructions

# Usage Instructions

---

### Continued

13. Only open the gate sufficiently to allow the load to empty.
14. When discharge is complete, close the gate fully and move the skip back to the ground.
15. After use ensure the skip is thoroughly washed out (see cleaning instructions below).
16. With the skip empty and clean, lower it to the ground and disconnect from the forklift. Disconnect the safety chain, remove the lynch pins and heel pins and reverse the forklift backward and clear of the skip. Replace the heel pins and lynch pins to prevent loss.

### Cleaning Instructions

1. The skip must be cleaned of all remaining concrete at the end of each work session, or more frequently if required. There can be no excuse for the unit to fail because of hard concrete residue.
2. Thorough cleaning can be achieved if the gate control spring is disconnected, this will allow you to open the gate fully for hosing down. Always take extreme caution when releasing the gate control. Do not tie the gate control lever in the open position.
3. Once thoroughly cleaned, the spring must be re-fitted to keep the gate closed. If you do not, concrete residue may set in the gate blade channels that will foul its operation.

## Original Working Instructions

# Safety Instructions

---

### Basic Safety

A site-specific Risk Assessment, and lift plan where applicable, must be completed by the responsible person before using this equipment to control risks, produce a safe system of work and ensure safety for you, your colleagues and others. Your risk assessment will determine the correct Personal Protective Equipment (PPE) for the task you are doing. You must use it. Conquip recommends that you should wear:

- Suitable clothing
- Gloves
- Hard hat
- Protective footwear (steel toecaps)
- Safety glasses



### Important Safety Notes

- Read these instructions before using this equipment. If there is anything you do not understand or if you have any concerns do not use this equipment. Contact your supervisor or Conquip Engineering Group for advice.
- You must check that you have considered all the safety requirements for the task you are doing and that this equipment is suitable.
- You must protect bystanders and the general public by preventing access to the working area.
- Do not use this equipment if you are tired, unwell or under the influence of alcohol or drugs. If you are taking any medicine or undergoing treatment you should inform your supervisor.

## Usage & Transportation

- Never unevenly load this equipment.
- The weight of the equipment, together with its attachments, must be added to the weight of the load when calculating the total load that will be imposed on the lifting apparatus / operating machine.
- This equipment must be used in conjunction with the load ratings of the lifting apparatus / operating machine. (Refer to the manufacturers' load ratings and original working instructions).
- Make sure you know how to use this equipment and understand all aspects of its operation in case of emergency.
- This equipment weighs more than 25kg. Do not lift or manhandle without machine assistance.
- Do not operate this equipment near overhead power lines.
- Take care in confined spaces, near ceilings or similar hazards. This equipment was designed for vertical lifting. Do not drag, or swing.
- Before operating this equipment, check that you have enough space for you to work safely and make sure that the working area is clear of hazards, obstructions and personnel.
- Before lowering equipment make sure that the landing zone is clear and capable of accepting the size and weight of the load.
- Crush Risk. Keep hands and feet clear of the equipment at all times to avoid injury.
- Do not exceed the maximum Working Load Limit (WLL) shown on the serial plate. Ensure that the WLL on the individual lift points is not exceeded.
- Before lifting, check that the load is secured, balanced and stable. Allow space for the equipment to move if the load shifts.
- Manoeuvre loaded or raised equipment carefully. Travel and turn slowly to avoid unit becoming unstable.

## Personnel

- All personnel must wear relevant personal protective equipment.
- Do not wear loose clothing or jewellery and tie back long hair to avoid becoming tangled or trapped in this equipment. You must make everyone in the work area aware of what you are doing.
- All personnel involved in the lifting operation must be competent to do so and must have been briefed in conjunction with this User Guide available from Conquip Engineering Group, the manufacturer.

## Equipment Maintenance & Cleaning

- It is mandatory that the equipment is thoroughly examined regularly, by a qualified engineer, to ensure compliance with relevant regulation/s. (Conquip recommend to carry out thorough examination every six months).
- This product may incorporate various loose and detachable items of lifting gear. Refer to the separate requirements for the safe use of those items.
- When not being used, store the unit in a clean, upright condition and in a safe place where it will be protected from thieves and unauthorised users.
- This equipment must be inspected by the responsible person before each use and then regularly, as determined by your risk assessment or working practice. If you have any concerns about condition or suitability do not use.

## Disclaimer

---

### Warranty

The products supplied by Conquip Engineering Group are all guaranteed by a 12 month warranty.

Apart from where exceptions apply, Conquip Engineering Group promises to repair or replace any fault which the Company considers to be due to defective material or workmanship within 12 months of the date of sale, at no additional cost.

- Faults arising from unauthorised alterations (see modifications section below for full details).
- Damage caused by abuse, neglect, misuse or falling.
- Damage caused because of failure to follow transportation, storage, loading, cleaning or operating instructions.
- Replacement or repair of components due to fair wear and tear.
- Any consequential damage or wear arising from the use or fitting of additional or non-standard parts.

### Modifications

If any third-party modifications or alterations, involving drilling, welding, cutting or distortion of materials in any form, are to be carried out on the product, Conquip Engineering Group must provide full written approval prior to the work being carried out.

Alterations, modifications, additions or repairs must be carried out by Conquip Engineering Group's recognised distributors, if they are not carrying out the work themselves.

Conquip Engineering Group operate a continuous improvement policy and therefore reserve the right to alter technical specifications and user guide details at any point without notice.

Conquip Engineering Group will not cover or reimburse any transportation and/or shipment costs to and from their premises or their recognised agents, or any material and/or labour costs for repair, replacement or assessment against a warranty claim.

Conquip Engineering Group and/or their directors, employees, insurers or recognised agents will not be held liable for consequential damages, losses or expenses relating to the inability to use the product correctly for its purpose.

# EC Declaration of Conformity

---

## In accordance with EN ISO 17050-1:2004

Declaration: As defined by the Machinery Directive 2006/42/EC and subsequent amendments

We, CONQUIP ENGINEERING GROUP, herewith declare that the following indicated equipment meets the fundamental health and safety requirements concerning the EU guide line(s), due to their design and manufacture.

This declaration will be rendered null and void if the machine is changed without our approval.

**Signed:**



**Dated: 2018**

**Garry Critchley, Managing Director**

<b>Product Code(s):</b>	CS214-00500 / CS214-01000
<b>EC Directive/ Regulation:</b>	2006/42/EC, Lifting Operations and Lifting Equipment Regulations 1998 Provision and Use of Work Equipment Regulations 1998
<b>Harmonised Standards:</b>	BS EN ISO 12100:2010
<b>General Description/ Designation:</b>	Concrete Forklift Skip – CS214-00500 / CS214-01000
<b>WLL:</b>	CS214-00500 = 1500kg CS214-01000 = 3000kg

## Important Notes

- This User Guide is for this Conquip product only.
- Any movements of the product must be thoroughly planned before the work commences to identify potential hazards and assess risk.
- All personnel involved in lifting and transportation of this product must have read this User Guide and must be properly briefed.
- You must be competent, alert and medically fit when using this equipment. If you have a medical condition, a mental or physical disability, you must seek advice from a medical professional before using this equipment.

Talking to us is easy

**We're here to help**

Call us on 0845 520 1101

Email us at [sales@cqegroup.com](mailto:sales@cqegroup.com)

[www.cqegroup.com](http://www.cqegroup.com)

**Conquip Engineering Group**

Waterbrook Estate, Alton, Hampshire, GU34 2UD