

User Guide

Powerbrush



Product Information

Overview

The Conquip Powerbrush is a hydraulic powered forklift sweeper that collects dirt and waste. The Powerbrush incorporates a large water tank and dispenser bar for even distribution of water for dust suppression. The unit is extremely durable and inexpensive to maintain. It can be fitted with an optional kerb brush.

The Powerbrush is a very cost effective, easy method to keep construction sites clean, helping keep sites tidy and safe at all times. It offers total flexibility and efficiency, utilising telehandlers' idle time.

Key Benefits

- Brushes can be replaced quickly, with just 7 brush adjustments, that can be easily height adjusted as they wear.
- Simple hydraulic system with a single 1-way hydraulic valve, reducing the number of wearing parts.
- Only 4 grease points for easy maintenance.
- Robust hopper design to ensure durability and protection from manhole covers.
- 3 wheels for maximum stability and the ability to follow uneven ground.
- Manufactured in the UK from high quality British and European steel and components.

Customisation Options

- The Powerbrush can be supplied with a kerb brush.

Flow Rate

- 90 litres per minute minimum requirement intermittent.
- 78 litres per minute minimum requirement continuous running.

Product Information Specification

Item	Product Code
Powerbrush	SA800AC-02100

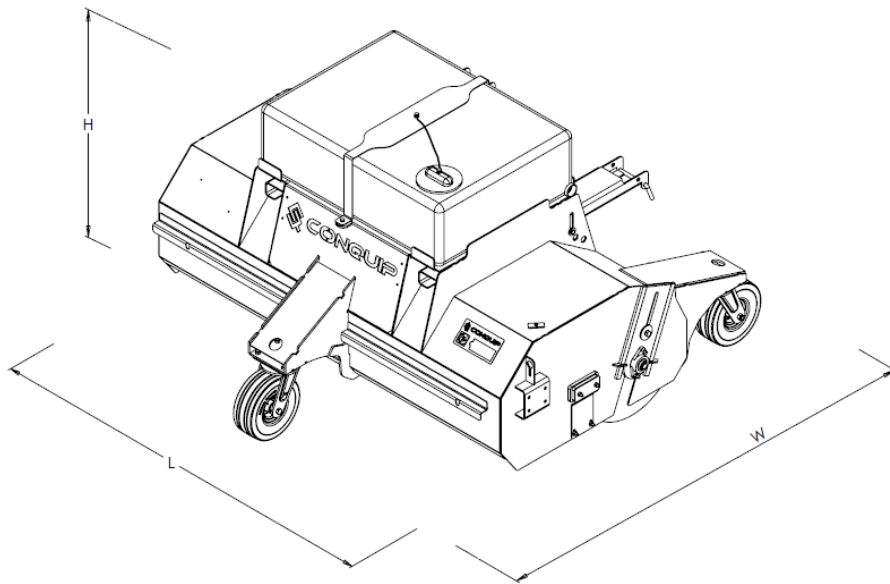

Dimensions without Kerb Brush

Height	Width	Length	Weight	Fork Pockets	Tank Capacity
1202mm	2340mm	2205mm	560kg	148 x 60mm	250 litres

Product Information Parts Diagram

Powerbrush

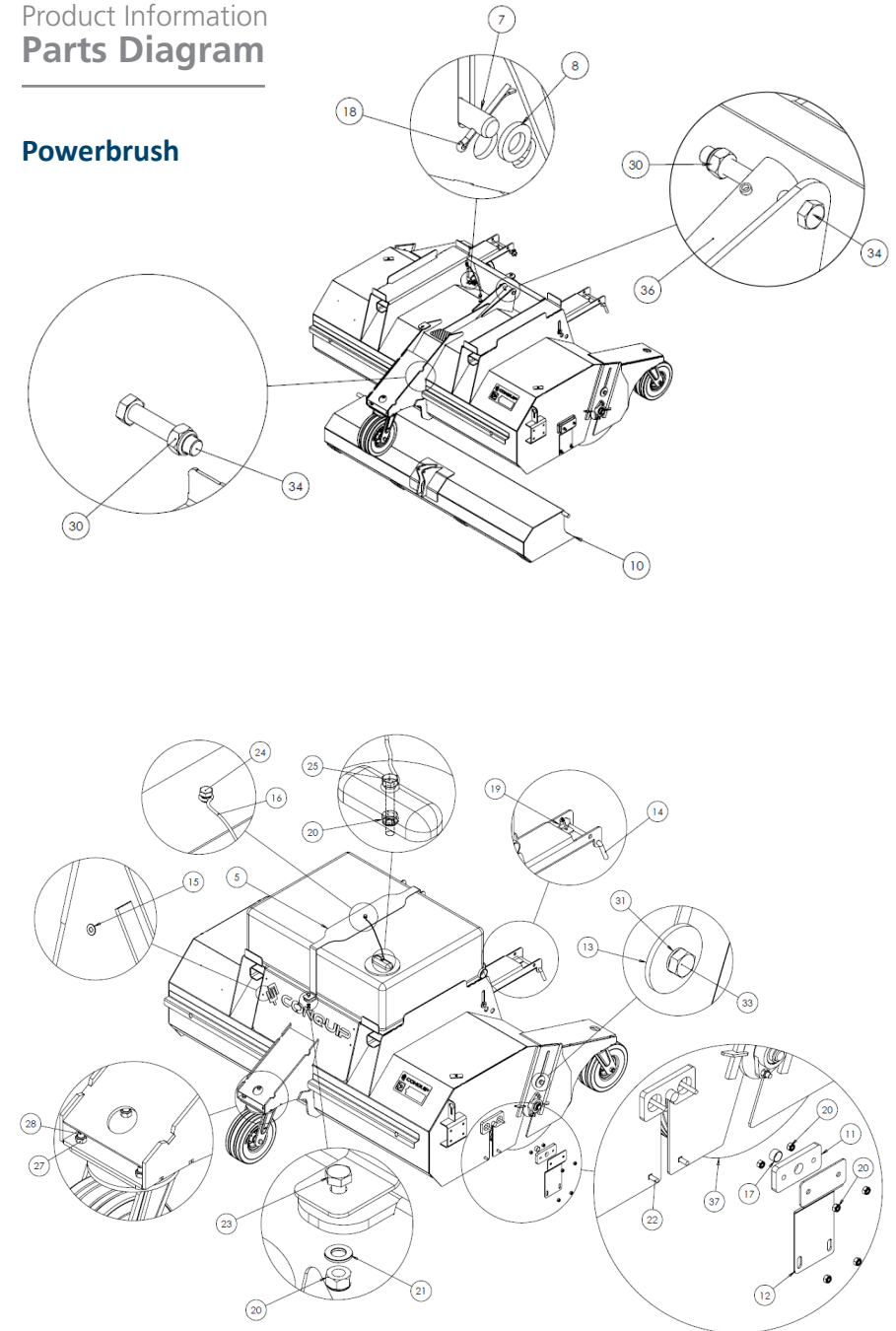

Product Information Parts Diagram

Powerbrush

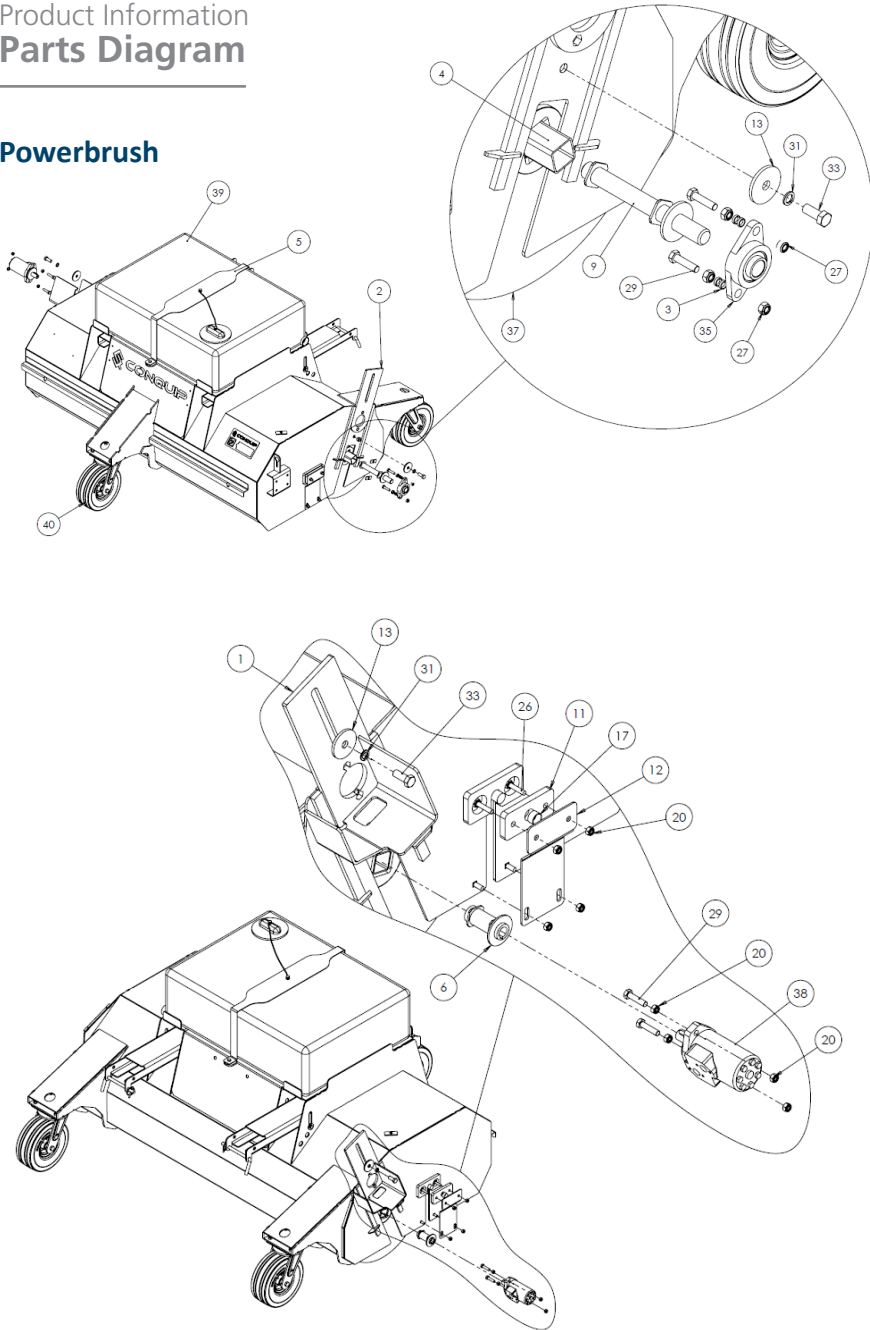

Product Information Parts Diagram

Powerbrush

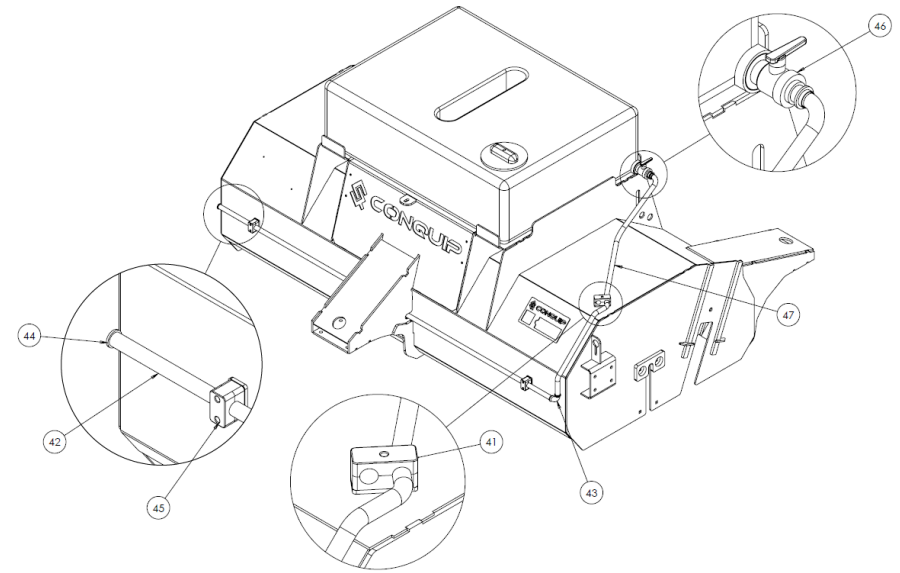

NOTE: These parts are for this model, they may differ for previous versions. Please contact Conquip with any queries.

Item Number	Part Number	Description	Quantity
1	ZZ220169	Brush Adjustment Assembly	1
2	ZZ220170	Brush Adjustment Assembly c/w Bearing	1
3	ZZ960079	Washer 4mm x OD: 15.5mm x ID:12.5mm	4
4	ZZ220173	Main Brush Shaft, Length: 2065mm	1
5	ZZ220174	Water Tank Strap	1
6	ZZ220187	Shaft Motor Insert Assembly	1
7	ZZ220176	Fork Pocket Retaining Pins	2
8	ZZ960078	Washer 6mm x OD:37mm x ID:21mm	2
9	ZZ220177	Shaft Bearing Insert Assembly	1
10	ZZ960077	Washer 6mm x OD:73mm x ID:30.5mm	1
11	ZZ220178	Hopper Bearing Bracket	2
12	ZZ220179	Hopper Safety Guard	2
13	ZZ960063	Washer 6mm x OD: 70mm x ID: 17mm	2
14	ZZ990000	Heel Pin, 16mm dia. Max Pocket Width 180mm (Single)	2
15	NS800804	4.8 x 20mm Alu Large Flange Blind (Pop) Rivets	4
16	ZZ990510	Coated Galvanised Restraint Wire, 500mm c/w Nylon Eye	1
17	ZZ960064	Sleeve Bearing, Oilon, OD: 25mm x ID:15mm x 28mm	2
18	ZZ220167	Splined Hub, 8mm Key, 100mm L, OD: 50mm \emptyset , ID: 25mm \emptyset	1
19	ZZ990009	Linch Pin 6mm x 42mm	4
20	NS800013	M10 Nyloc Nut	18
21	NS800262	M10 Steel Washer A BZP	2
22	NS800888	M10 x 30mm Coach Bolt	4
23	NS800666	M10 X 30 Hex Head set BZP	2
24	NS800066	M10 x 35 8.8 HT Hex Head Set Screw BZP	1
25	NS800622	M8 x 30 Hex Head Set Screw BZP	1
26	NS800860	M10x60 Coach Bolt	4

NOTE: These parts are for this model, they may differ for previous versions. Please contact Conquip with any queries.

Item Number	Part Number	Description	Quantity
27	NS800015	M12 Nyloc Nut BZP	16
28	NS800889	M12 x 40 Hex Head Set Screws 8.8 HT	12
29	NS800817	M12 x 50 8.8 HT BZP Hex Set Screws	4
30	NS800121	M16 Nyloc Nuts BZP	2
31	NS800249	M16 Spring Washer	2
32	NS800566	M16 x 130 Bolts BZP	1
33	NS800379	M16 x 40 Set Screw	2
34	NS800801	M16 x 70 Bolt BZP	1
35	ZZ220003	Flanged Bearing, 30mm c/w Grease Nipple	1
36	ZZ960065	Hydraulic Cylinder, 20mm \emptyset Piston, 400mm Stroke	1
37	ZZ270000	Brush 100% PPN 295mm x 600mm \emptyset	7
38	ZZ220185	Hydraulic Motor AGMR 160	1
39	ZZ990506	Water Tank, 250L, c/w Conquip Branding	1
40	ZZ270141	Swivel Castor, Heavy Duty, 305mm Wheel Diameter	3
41	ZZ220180	Hydraulic Double Hose Clamp, 3/8"	2
42	ZZ220042	2m UPVC Pipe, ID: 1/2"	1
43	ZZ220040	90° Elbow, 1/2" Thread, 1/2" Solvent UPVC	1
44	ZZ220043	End Cap, ID: 1/2" Solvent UPVC	1
45	ZZ220181	Hydraulic Single Hose Clamp, 1/2"	2
46	ZZ220126	Water Tap	1
47	ZZ220125	PVC Water Hose	1

Product Information Parts Diagram

Powerbrush Kerb Brush

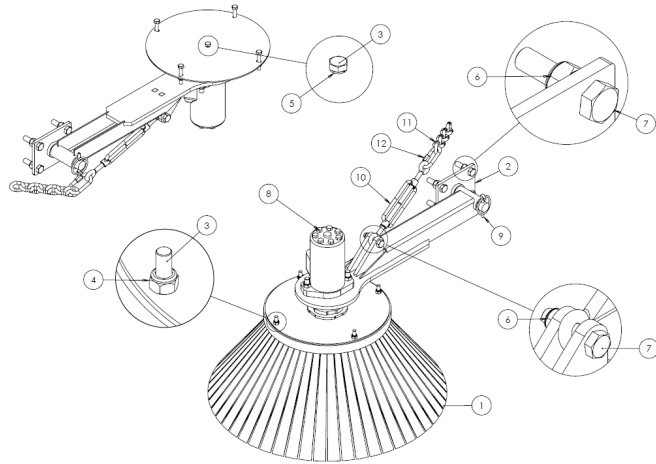

NOTE: These parts are for this model, they may differ for previous versions. Please contact Conquip with any queries.

Item Number	Part Number	Description	Quantity
1	ZZ220051	Poly Kerb Brush, 4 Fixing Bolts	1
2	ZZ220054	Kerb Brush Bracket	1
3	NS800370	M8 x 50 HT Hex Bolt BZP	5
4	NS800011	M8 Nylon Inset Nut BZP	4
5	NS800378	M8 Spring Washer	1
6	NS800817	M12 x 50 8.8 HT BZP Hex Set Screws	7
7	NS800015	M12 Nylon Inset Nut BZP	4
8	ZZ220185	Hydraulic Motor AGMR 160	1
9	ZZ990009	Linch Pin 6mm x 42mm	1
10	ZZ220054	Kerb Brush Bracket	1
11	ZZ990515	Chain, Galvanised, 8mm x 52mm x 32mm Long Link (per metre)	4
12	ZZ110009	Quick Link, 8mm	1

Product Information Parts Diagram

Powerbrush Kerb Brush Hydraulics

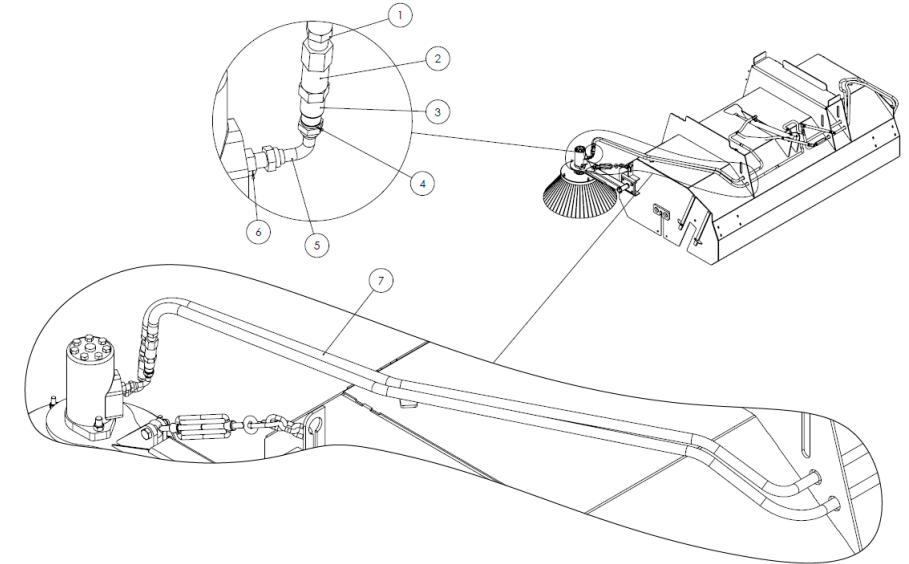

NOTE: These parts are for this model, they may differ for previous versions. Please contact Conquip with any queries.

Item Number	Part Number	Description	Quantity
1	ZZ220071	Male-Male Adaptor 3/8" X 3/8" BSP	3
2	ZZ220097	1/2" Flat Face Female Quick Release Coupling	2
3	ZZ220096	1/2" Flat Face male Quick Release Coupling	2
4	ZZ990561	Rubber Bonded Seal 1/2" (Dowty Washer)	4
5	ZZ220202	Male-Female Adaptor Swept 90° 1/2" x 1/2" BSP	2
6	ZZ220070	Male-Male Adaptor, 1/2" X 1/2" BSP	2
7	ZZ220203	Hydraulic Hose, 3/8" Ø, 200mm, Ends: 3/8" F / 1/2" F	2

Product Information

Parts Diagram

Powerbrush without Kerb Brush Hydraulics

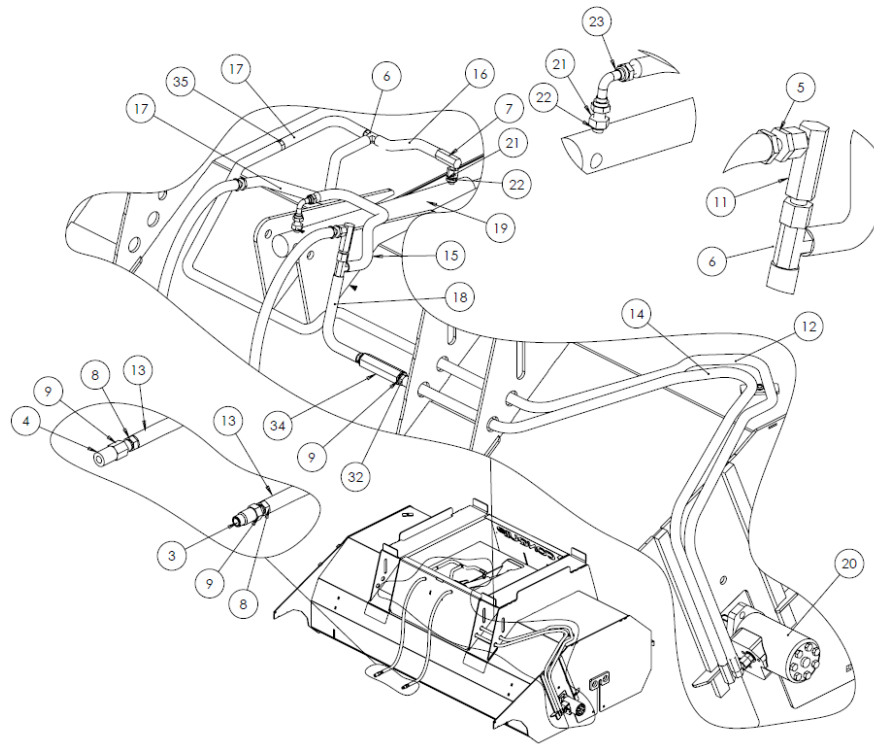

NOTE: These parts are for this model, they may differ for previous versions. Please contact Conquip with any queries.

Item Number	Part Number	Description	Quantity
1	ZZ220071	Male-Male Adaptor 3/8" X 3/8" BSP	5
2	ZZ990562	Rubber Bonded Seal 3/8" (Dowty Washer)	4
3	ZZ220092	3/8" Flat Face male Quick Release Coupling	1
4	ZZ220093	3/8" Flat Face Female Quick Release Coupling	1
5	ZZ220193	Bulkhead Fitting c/w Locknut, 3/8" BSP	2
6	ZZ220123	3/8" M/M/M Tee Piece	2
7	ZZ220122	Male-Female Adaptor Compact 90° 3/8" x 3/8" BSP	3
8	ZZ220137	Male-Male Adaptor, 3/8" X 1/2" BSP	6
9	ZZ990561	Rubber Bonded Seal 1/2" (Dowty Washer)	6
10	ZZ220138	1 way Valve Female to Female 1/2in	1
11	ZZ220194	Female-Female Adaptor Compact 90° 3/8" x 3/8" BSP	1
12	ZZ220195	Hydraulic Hose, 3/8" Ø, 2200mm, Ends: 3/8" F / 3/8" F	1
13	ZZ220184	Hydraulic Hose, 3/8" Ø, 2100mm, Ends: 3/8" F / 3/8" F	2
14	ZZ220196	Hydraulic Hose, 3/8" Ø, 1600mm, Ends: 3/8" F / 3/8" F	1
15	ZZ220197	Hydraulic Hose, 3/8" Ø, 470mm, Ends: 3/8" F / 3/8" F	1
16	ZZ220198	Hydraulic Hose, 3/8" Ø, 2100mm, Ends: 3/8" F / 3/8" Compact 90° F	1
17	ZZ220199	Hydraulic Hose, 3/8" Ø, 220mm, Ends: 3/8" F / 3/8" F	2
18	ZZ220200	Hydraulic Hose, 3/8" Ø, 170mm, Ends: 3/8" F / 3/8" F	1
19	ZZ960065	Hydraulic Cylinder, 20mm Ø Piston, 400mm Stroke	1
20	ZZ220185	Hydraulic Motor AGMR 160	1
21	ZZ220201	Male-Male Adaptor, 1/4" X 3/8" BSP	2
22	ZZ990563	Rubber Bonded Seal 1/4" (Dowty Washer)	2

Original Working Instructions

Usage Instructions

Important Usage Notes

- The Powerbrush is supplied with a heel pin; this must be fitted correctly before use. If the heel pin is missing do not use the equipment, do not use alternatives, but contact Conquip Engineering Group for a replacement.

Connecting the Powerbrush to your Forklift

1. To attach the Powerbrush to a forklift, set the machine's forks to the correct width for the Powerbrush fork pockets. Make sure that they are equidistant from the centre.
2. Drive the telehandler to the Powerbrush aligning the forks with the Powerbrush fork pockets.
3. Double check that all is correctly aligned, then move the telehandler forward until the forks are fully inserted into the fork pockets.
4. Apply the park brake and switch off the forklift engine.
5. Release any pressure in the auxiliary hydraulic line of the forklift by operating the control lever with the engine off.
6. Remove the heel pins from the heel pin storage by removing the linch pin.
7. Insert both heel pins into the holes behind the heel of the forks and use the linch pins to lock the heel pins in place, securing the forks within the Powerbrush fork pockets.
8. Take the 2 hydraulic hoses from the Powerbrush and connect them to the 2 outputs on the arm of the forklift. The quick release female on the Powerbrush connects to the male on the forklift. The quick release male on the Powerbrush connects to the female on the forklift. The Powerbrush is now ready for use.

NOTE: Configuration may differ on different forklift make and models.

Original Working Instructions

Usage Instructions

Preparing the Powerbrush for Use

1. Prior to using the Powerbrush, the water tank needs to be filled up with water. Ensure that the outlet tap is turned off whilst filling. Unscrew the cap from the tank and fill the tank through the hole with a water hose. The tank will hold 250 litres of water.
2. Ensure that the brush is adjusted correctly. Always set up the Powerbrush on a level surface. The bristles should be touching the ground very slightly with a small deflection where the bristle meets the floor.
3. To adjust the brush, undo bolt A on one side of the brush (see diagram) and apply a small amount of pressure to push the brush to the ground. Re-tighten the bolt. Repeat this procedure to the other side of the brush.

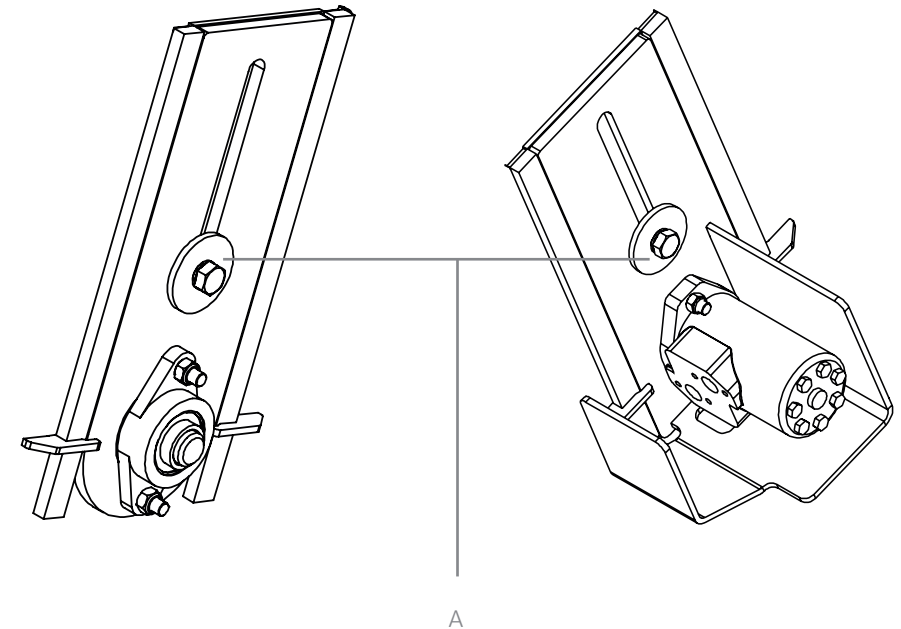

Original Working Instructions

Usage Instructions

Using the Powerbrush

1. Open the water tap, to allow water to dribble evenly from the dust suppression bar at the front of the Powerbrush.
2. Lower the brush to the floor and ensure that the floating forks are in the centre of the floating area and forks are level.
3. Activate the brush by operating the hydraulic circuit of the forklift or telehandler.
4. Drive forward at a suitable speed to achieve the desired sweep results.
5. Once the hopper is full, lift the Powerbrush to a suitable location and reverse the flow of the hydraulic circuit to empty the hopper.

Removing the Powerbrush from your Forklift

1. To remove the Powerbrush from a forklift, first park in a suitable place.
2. Apply the park brake and switch of the forklift engine.
3. Operate the auxiliary control lever, without the engine running, to release the pressure and close the hopper.
4. Remove the hydraulic hoses from the 2 outputs on the arm of the forklift. Use gloves as the connections will be hot due to hydraulic oil passing through the connections.
5. Remove the linch pins and replace in the heel pin storage holes.
6. Drive the forklift away.

Original Working Instructions

Usage Instructions

Assembly Instructions for Optional Kerb Brush

1. Bolt on the Kerb Brush Pin Bracket (ZZ220054) to the Powerbrush, using 4 M12 x 50mm bolts, provided.
2. Slide the gulley brush arm onto the pin.
3. Insert the linch pin to secure the arm to the bracket.
4. Pass the chain through the anchor point to a position where the bristle of the kerb brush is just off the floor.
5. Use the turn buckle for fine adjustment to a point where the front bristles are just touching the floor with a small amount of deflection.

Original Working Instructions

Usage Instructions

Assembly Instructions for replacing the main brushes

1. Remove the bolt and washer from the top plate fixing on both sides of the Powerbrush body, and detach the hydraulic hoses.
2. With the fixings now removed on both sides, lift the Powerbrush with the forklift. The brush, along with any fixings attached, will now slide down the plate guide and detach itself from the Powerbrush body.
3. Once the brush is fully detached from the Powerbrush body, detach the fixing, bearing and bearing shaft (as shown).
4. Once fixing and bearing parts are removed, the brush sections with the brush can pull out.

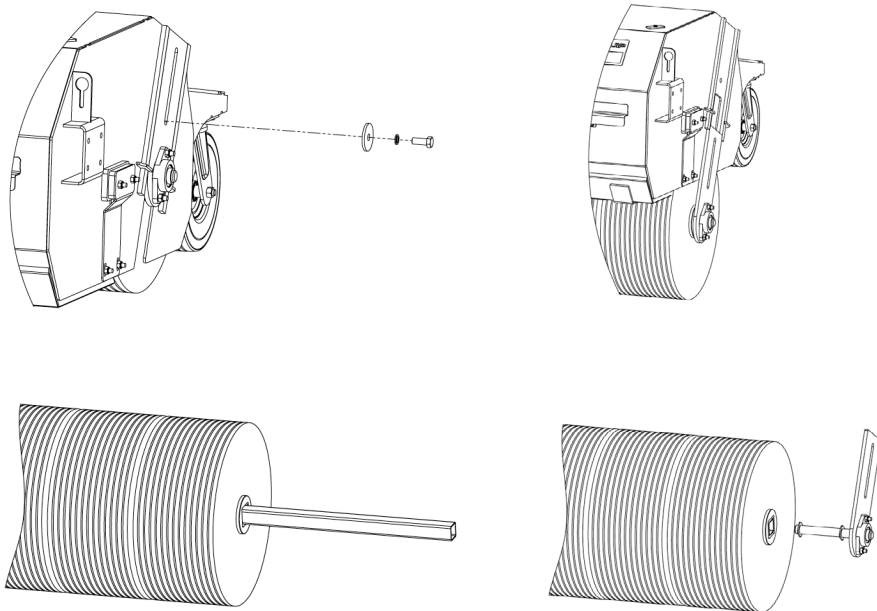

Original Working Instructions

Safety Instructions

Basic Safety

A site-specific Risk Assessment, and lift plan where applicable, must be completed by the responsible person before using this equipment to control risks, produce a safe system of work and ensure safety for you, your colleagues and others. Your risk assessment will determine the correct Personal Protective Equipment (PPE) for the task you are doing. You must use it. Conquip recommends that you should wear:

- Suitable clothing
- Gloves
- Hard hat
- Protective footwear (steel toecaps)
- Safety glasses



Important Safety Notes

- Read these instructions before using this equipment. If there is anything you do not understand or if you have any concerns do not use this equipment. Contact your supervisor or Conquip Engineering Group for advice.
- You must check that you have considered all the safety requirements for the task you are doing and that this equipment is suitable.
- You must protect bystanders and the general public by preventing access to the working area.
- Do not use this equipment if you are tired, unwell or under the influence of alcohol or drugs. If you are taking any medicine or undergoing treatment you should inform your supervisor.

Usage & Transportation

- Never unevenly load this equipment.
- The weight of the equipment, together with its attachments, must be added to the weight of the load when calculating the total load that will be imposed on the lifting apparatus / operating machine.
- This equipment must be used in conjunction with the load ratings of the lifting apparatus / operating machine. (Refer to the manufacturers' load ratings and original working instructions).
- Make sure you know how to use this equipment and understand all aspects of its operation in case of emergency.
- This equipment weighs more than 25kg. Do not lift or manhandle without machine assistance.
- Do not operate this equipment near overhead power lines.
- Take care in confined spaces, near ceilings or similar hazards. This equipment was designed for vertical lifting. Do not drag, or swing.
- Before operating this equipment, check that you have enough space for you to work safely and make sure that the working area is clear of hazards, obstructions and personnel.
- Before lowering equipment make sure that the landing zone is clear and capable of accepting the size and weight of the load.
- Crush Risk. Keep hands and feet clear of the equipment at all times to avoid injury.
- Do not exceed the maximum Working Load Limit (WLL) shown on the serial plate. Ensure that the WLL on the individual lift points is not exceeded.

Personnel

- All personnel must wear relevant personal protective equipment.
- Do not wear loose clothing or jewellery and tie back long hair to avoid becoming tangled or trapped in this equipment. You must make everyone in the work area aware of what you are doing.
- All personnel involved in the lifting operation must be competent to do so and must have been briefed in conjunction with this User Guide available from Conquip Engineering Group, the manufacturer.

Equipment Maintenance & Cleaning

- It is mandatory that the equipment is thoroughly examined regularly, by a qualified engineer, to ensure compliance with relevant regulation/s. (Conquip recommend to carry out thorough examination every six months).
- This product may incorporate various loose and detachable items of lifting gear. Refer to the separate requirements for the safe use of those items.
- When not being used, store the unit in a clean, upright condition and in a safe place where it will be protected from thieves and unauthorised users.
- This equipment must be inspected by the responsible person before each use and then regularly, as determined by your risk assessment or working practice. If you have any concerns about condition or suitability do not use.

Disclaimer

Warranty

The products supplied by Conquip Engineering Group are all guaranteed by a 12 month warranty.

Apart from where exceptions apply, Conquip Engineering Group promises to repair or replace any fault which the Company considers to be due to defective material or workmanship within 12 months of the date of sale, at no additional cost.

- Faults arising from unauthorised alterations (see modifications section below for full details).
- Damage caused by abuse, neglect, misuse or falling.
- Damage caused because of failure to follow transportation, storage, loading, cleaning or operating instructions.
- Replacement or repair of components due to fair wear and tear.
- Any consequential damage or wear arising from the use or fitting of additional or non-standard parts.

Modifications

If any third-party modifications or alterations, involving drilling, welding, cutting or distortion of materials in any form, are to be carried out on the product, Conquip Engineering Group must provide full written approval prior to the work being carried out.

Alterations, modifications, additions or repairs must be carried out by Conquip Engineering Group's recognised distributors, if they are not carrying out the work themselves.

Conquip Engineering Group operate a continuous improvement policy and therefore reserve the right to alter technical specifications and user guide details at any point without notice.

Conquip Engineering Group will not cover or reimburse any transportation and/or shipment costs to and from their premises or their recognised agents, or any material and/or labour costs for repair, replacement or assessment against a warranty claim.

Conquip Engineering Group and/or their directors, employees, insurers or recognised agents will not be held liable for consequential damages, losses or expenses relating to the inability to use the product correctly for its purpose.

EC Declaration of Conformity

In accordance with EN ISO 17050-1:2004

Declaration: As defined by the Machinery Directive 2006/42/EC and subsequent amendments

We, CONQUIP ENGINEERING GROUP, herewith declare that the following indicated equipment meets the fundamental health and safety requirements concerning the EU guide line(s), due to their design and manufacture.

This declaration will be rendered null and void if the machine is changed without our approval.

Signed:



Dated: 2018

Garry Critchley, Managing Director

Product Code(s):	SA800AC-02100
EC Directive/Regulation:	2006/42/EC, Provision and Use of Work Equipment Regulations 1998
Harmonised Standards:	BS EN ISO 12100:2010
General Description/Designation:	Powerbrush – SA800AC-02100
WLL:	SA800AC-02100 = N/A

Important Notes

- This User Guide is for this Conquip product only.
- Any movements of the product must be thoroughly planned before the work commences to identify potential hazards and assess risk.
- All personnel involved in lifting and transportation of this product must have read this User Guide and must be properly briefed.
- You must be competent, alert and medically fit when using this equipment. If you have a medical condition, a mental or physical disability, you must seek advice from a medical professional before using this equipment.

Talking to us is easy

We're here to help

Call us on 0845 520 1101

Email us at sales@cqegroup.com

www.cqegroup.com

Conquip Engineering Group

Waterbrook Estate, Alton, Hampshire, GU34 2UD