

User Guide

Autolock Tipping Skip

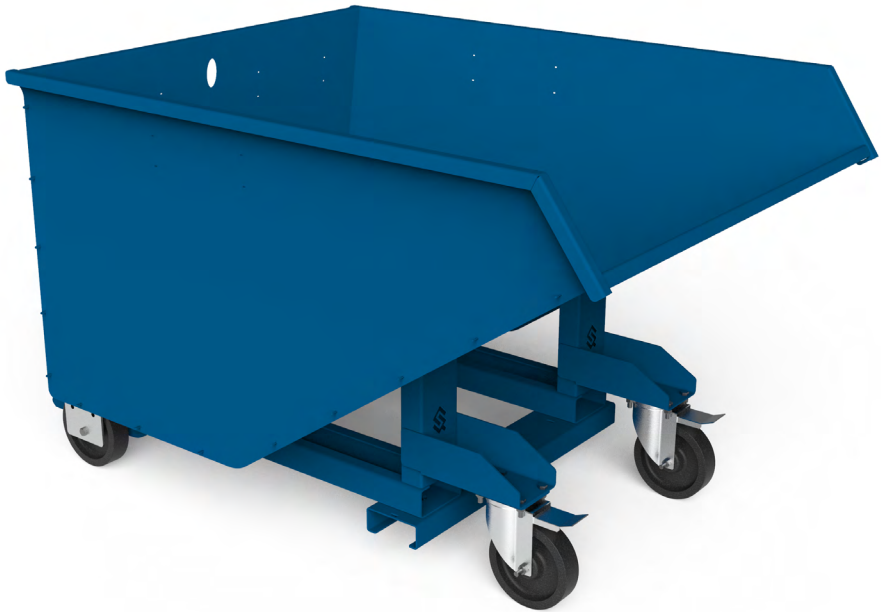

Product Information Overview

The Conquip Autolock Tipping Skip is the choice for many sites and leading plant companies. Its primary function is for the transportation of waste material. Autolock cannot be accidentally tipped as the skip is emptied by adjusting the angle of the telehandlers forks.

A gas assisted ram ensures automatic locking of the skip to the forks and its unique design guarantees 100% restraint on the forks. Simply drive your forks into the pockets and the Autolock mechanism will clamp itself to your machine. To detach simply land the skip, the Autolock will release and you can reverse away.









Designed to withstand the daily rigours of construction sites these skips are heavy duty, thoroughly tested and built to last.

Key Benefits

- Standard width fork pockets reduces the need for adjustment of forks.
- Autolock system eliminates the need to attach safety restraint chains.
- Utilising the telehandlers' tilt function to tip the load ensures that the Autolock cannot be accidentally tipped.
- No levers or cables are required to discharge the Autolock so the driver can remain safely seated within the cab.
- Designed and manufactured within the United Kingdom from British and European steel.

Customisation Options

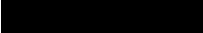
- Available with castor wheels (these consist of two swivel wheels for the front and two fixed wheels for the rear).
- Painted in the Institute of Civil Engineers standard colours of your choice (see colour chart right).
- Crane lift models available.
- Customer branding.

Colour	Use
	Asbestos
	Hazardous
	Clinical
	Plasterboard
	Inert
	Mixed
	Metal
	Wood
	Packaging

Product Information Specification

Item	Product Code
Standard Autolock	FA800AD-01200
Autolock with Casters	FA801-01200
Cranelift Autolock	CA128-01200
Cranelift Autolock with Casters	CA134-01200

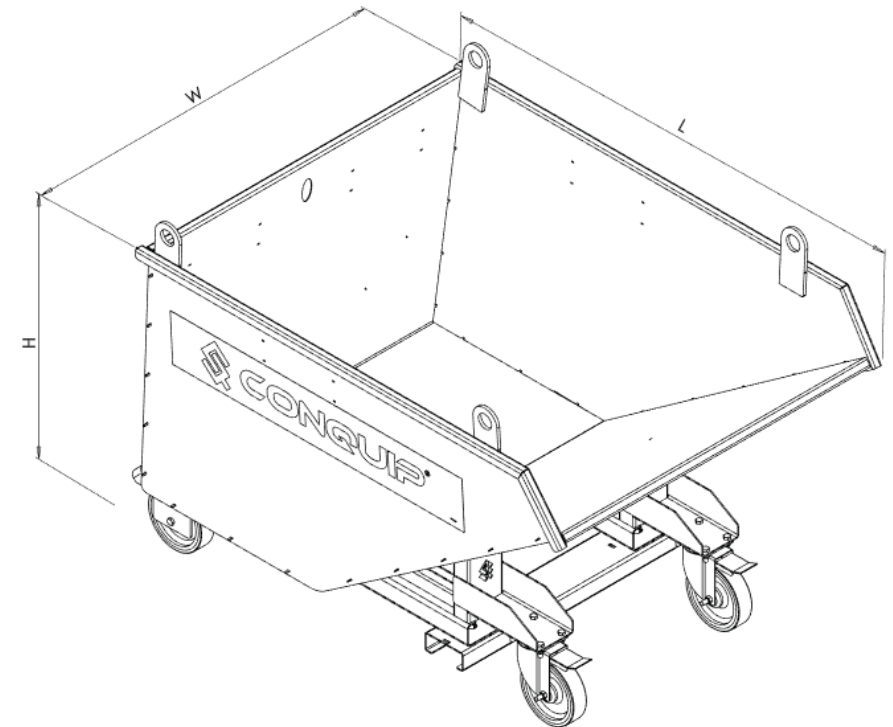

¹Working Load Limit

Product Code	Height	Width	Length	Weight	WLL ¹	Capacity	Fork Pocket
FA800AD-01200	964mm	1224mm	1818mm	160kg	2000kg	1200 litres	142 x 62mm
FA801-01200	1051mm	1224mm	1818mm	160kg	2000kg	1200 litres	142 x 62mm
CA128-01200	1078mm	1224mm	1818mm	160kg	1000kg	1200 litres	142 x 62mm
CA134-01200	1160mm	1224mm	1818mm	160kg	1000kg	1200 litres	142 x 62mm

Product Information
Parts Diagrams

Standard Autolock & Cranelift Autolock

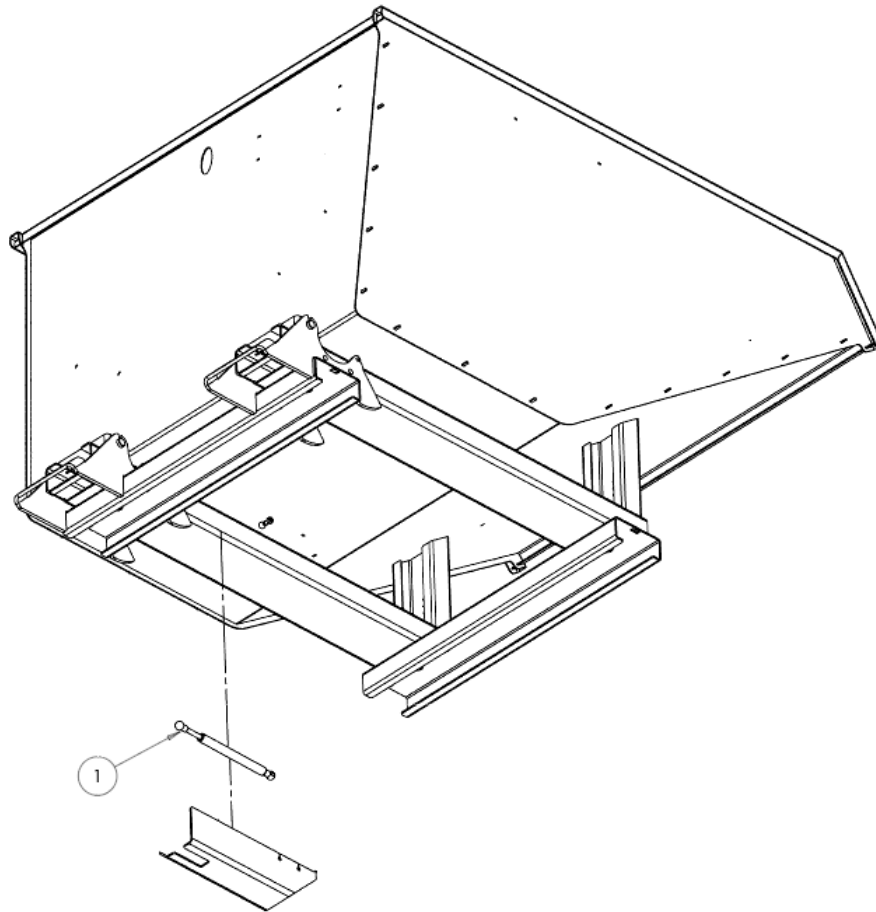

NOTE: These parts are for this model, they may differ for previous versions. Please contact Conquip with any queries.

Item Number	Part Number	Description	Quantity
1	ZZ110015	Gas Strut	1

Product Information
Parts Diagrams

Autolock with Castors & Cranelift Autolock with Castors

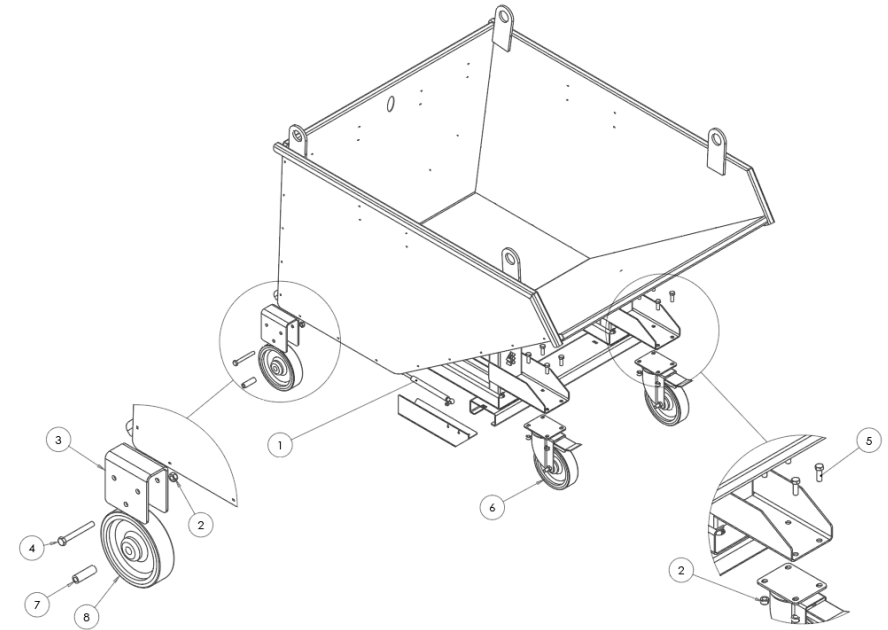

NOTE: These parts are for this model, they may differ for previous versions. Please contact Conquip with any queries.

Item Number	Part Number	Description	Quantity
1	ZZ110015	Gas Strut	1
2	NS800015	M12 Nyloc Nut	10
3	ZZ110148	Rear Castor Bracket	2
4	NS800234	M12 x 100 Hex Head Set Screw	2
5	NS800014	M12 x 35 Hex Head Set Screw	8
6	ZZ110097	Swivel Braked Castor Wheel 200mm Ø	2
7	ZZ110110	Tube 61 x 20(ODØ) 12(IDØ)mm	2
8	ZZ110098	Polyurethane Wheel 200mm Ø	2

Original Working Instructions

Usage Instructions

Use with a Telehandler

1. Set the telehandler's forks to the correct width for the skip's fork pockets. Make sure that they are equidistant from the centre carriage.
2. Drive the telehandler to the skip aligning the forks with the skip's fork pockets.
3. Double check that all is correctly aligned, then move the telehandler forward until the forks are fully inserted into the fork pockets.

Autolock Mechanism Instructions

Once the forks are driven fully into the fork pockets, upon lifting the Autolock mechanism will automatically rise onto the locked position. IMPORTANT: If the skip cannot be secured correctly do not continue, contact Conquip Engineering Group for advice. Only load the skip when fully lowered to the ground, load the skip ensuring the load is no wider, longer or higher than the skip's side walls. Do not overload by volume or by weight.

1. Once ready, clear all personnel from the work area. Raise the unit just enough to allow sufficient clearance from the ground when traveling.
2. Drive the telehandler to the discharge area. If discharging into a traditional skip, raise the unit so that it clears the walls of the skip then drive forward until positioned over the skip.
3. Using the tilt function on the telehandler, empty the skip of its contents, return the skip to the horizontal position, return to the loading area.
4. The skip can be removed from the telehandler simply by landing on level ground and reversing away.

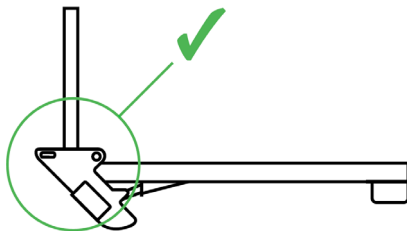
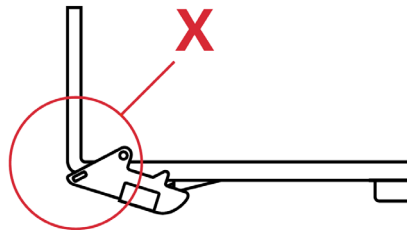

Original Working Instructions

Usage Instructions

Instructions for Use with a Crane

1. Connect the 4 points lifting chains to the respective 4 lifting eyes on the skip.
2. Once the chains are secured, carry out a test lift. Then the crane operator should lift the skip and transport to the correct location on site.
3. When the skip is safely on the ground, detach the chains and store in a safe place.

Important Usage Notes

- Ensure the work area is clear of all obstructions.
- Check that the skip is suitably rated to lift the load and of the correct size.
- Ensure adequate room around the unit for the operator to work safely.
- Use a suitably rated 4-leg lifting chain, with self-locking hooks.
- Take care not to tangle the chains when attaching to the skip.
- Always use a signaller that can clearly communicate with the crane operator.

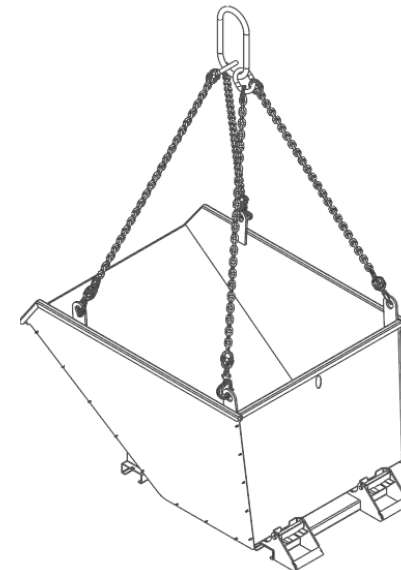

Original Working Instructions

Safety Instructions

Basic Safety

A site-specific Risk Assessment, and lift plan where applicable, must be completed by the responsible person before using this equipment to control risks, produce a safe system of work and ensure safety for you, your colleagues and others. Your risk assessment will determine the correct Personal Protective Equipment (PPE) for the task you are doing. You must use it. Conquip recommends that you should wear:

- Suitable clothing
- Gloves
- Hard hat
- Protective footwear (steel toecaps)
- Safety glasses



Important Safety Notes

- Read these instructions before using this equipment. If there is anything you do not understand or if you have any concerns do not use this equipment. Contact your supervisor or Conquip Engineering Group for advice.
- You must check that you have considered all the safety requirements for the task you are doing and that this equipment is suitable.
- You must protect bystanders and the general public by preventing access to the working area.
- Do not use this equipment if you are tired, unwell or under the influence of alcohol or drugs. If you are taking any medicine or undergoing treatment you should inform your supervisor.

Usage & Transportation

- Never unevenly load this equipment.
- The weight of the equipment, together with its attachments, must be added to the weight of the load when calculating the total load that will be imposed on the lifting apparatus / operating machine.
- This equipment must be used in conjunction with the load ratings of the lifting apparatus / operating machine. (Refer to the manufacturers' load ratings and original working instructions).
- Make sure you know how to use this equipment and understand all aspects of its operation in case of emergency.
- This equipment weighs more than 25kg. Do not lift or manhandle without machine assistance.
- Do not operate this equipment near overhead power lines.
- Take care in confined spaces, near ceilings or similar hazards. This equipment was designed for vertical lifting. Do not drag, or swing.
- Before operating this equipment, check that you have enough space for you to work safely and make sure that the working area is clear of hazards, obstructions and personnel.
- Before lowering equipment make sure that the landing zone is clear and capable of accepting the size and weight of the load.
- Crush Risk. Keep hands and feet clear of the equipment at all times to avoid injury.
- Do not exceed the maximum Working Load Limit (WLL) shown on the serial plate. Ensure that the WLL on the individual lift points is not exceeded.
- Before lifting, check that the load is secured, balanced and stable. Allow space for the equipment to move if the load shifts.
- Manoeuvre loaded or raised equipment carefully. Travel and turn slowly to avoid unit becoming unstable.

Personnel

- All personnel must wear relevant personal protective equipment.
- Do not wear loose clothing or jewellery and tie back long hair to avoid becoming tangled or trapped in this equipment. You must make everyone in the work area aware of what you are doing.
- All personnel involved in the lifting operation must be competent to do so and must have been briefed in conjunction with this User Guide available from Conquip Engineering Group, the manufacturer.

Equipment Maintenance & Cleaning

- It is mandatory that the equipment is thoroughly examined regularly, by a qualified engineer, to ensure compliance with relevant regulation/s. (Conquip recommend to carry out thorough examination every six months).
- This product may incorporate various loose and detachable items of lifting gear. Refer to the separate requirements for the safe use of those items.
- When not being used, store the unit in a clean, upright condition and in a safe place where it will be protected from thieves and unauthorised users.
- This equipment must be inspected by the responsible person before each use and then regularly, as determined by your risk assessment or working practice. If you have any concerns about condition or suitability do not use.

Disclaimer

Warranty

The products supplied by Conquip Engineering Group are all guaranteed by a 12 month warranty.

Apart from where exceptions apply, Conquip Engineering Group promises to repair or replace any fault which the Company considers to be due to defective material or workmanship within 12 months of the date of sale, at no additional cost.

- Faults arising from unauthorised alterations (see modifications section below for full details).
- Damage caused by abuse, neglect, misuse or falling.
- Damage caused because of failure to follow transportation, storage, loading, cleaning or operating instructions.
- Replacement or repair of components due to fair wear and tear.
- Any consequential damage or wear arising from the use or fitting of additional or non-standard parts.

Modifications

If any third-party modifications or alterations, involving drilling, welding, cutting or distortion of materials in any form, are to be carried out on the product, Conquip Engineering Group must provide full written approval prior to the work being carried out.

Alterations, modifications, additions or repairs must be carried out by Conquip Engineering Group's recognised distributors, if they are not carrying out the work themselves.

Conquip Engineering Group operate a continuous improvement policy and therefore reserve the right to alter technical specifications and user guide details at any point without notice.

Conquip Engineering Group will not cover or reimburse any transportation and/or shipment costs to and from their premises or their recognised agents, or any material and/or labour costs for repair, replacement or assessment against a warranty claim.

Conquip Engineering Group and/or their directors, employees, insurers or recognised agents will not be held liable for consequential damages, losses or expenses relating to the inability to use the product correctly for its purpose.

EC Declaration of Conformity

In accordance with EN ISO 17050-1:2004

Declaration: As defined by the Machinery Directive 2006/42/EC and subsequent amendments

We, CONQUIP ENGINEERING GROUP, herewith declare that the following indicated equipment meets the fundamental health and safety requirements concerning the EU guide line(s), due to their design and manufacture.

This declaration will be rendered null and void if the machine is changed without our approval.

Signed:



Dated: 2018

Garry Critchley, Managing Director

Product Code(s):

FA800AD-01200 / FA801-01200 / CA128-01200 / CA134-01200

EC Directive/Regulation:

2006/42/EC,
Lifting Operations and Lifting Equipment Regulations 1998
Provision and Use of Work Equipment Regulations 1998

Harmonised Standards:

BS EN ISO 12100:2010

General Description/Designation:

Standard Autolock Tipping Skip – FA800AD-01200
Autolock with Castors Tipping Skip- FA801-01200
Crane Lift Autolock Tipping Skip- CA128-01200
Crane Lift Autolock with Castors Tipping Skip- CA134-01200

WLL:

FA800AD-01200 / FA801-01200 = 2000kg
CA128-01200 / CA134-01200 = 1000kg

Important Notes

- This User Guide is for this Conquip product only.
- Any movements of the product must be thoroughly planned before the work commences to identify potential hazards and assess risk.
- All personnel involved in lifting and transportation of this product must have read this User Guide and must be properly briefed.
- You must be competent, alert and medically fit when using this equipment. If you have a medical condition, a mental or physical disability, you must seek advice from a medical professional before using this equipment.

Talking to us is easy

We're here to help

Call us on 0845 520 1101

Email us at sales@cqegroup.com

www.cqegroup.com

Conquip Engineering Group

Waterbrook Estate, Alton, Hampshire, GU34 2UD

Copyright © 2018 Conquip Engineering Group. All Rights Reserved.
Autolock Tipping Skip User Guide - Issue 4